

The HN49 is a heavy duty needle valve that features an industrial strength stem and bonnet, and enhanced packing arrangement, all designed to handle the tough conditions of high pressure and high temperature services.

With a multitude of configurations available, you will find a model to meet your varying needs. The HN49 is produced in 1/4" (DN8), 3/8" (DN10), 1/2" (DN15), 3/4" (DN20) and 1" (DN25) sizes, and can be provided with male or female threaded connections, male or female socket weld ends, or tube end connections. For corrosive or other volatile applications, the HN49 can be specified in a variety of materials, including Monel, Alloy 20, Titanium, and Hastelloy.

Refer to page four for information concerning the 10,000# bonnet.



Features and Benefits

- **Wide Selection of Packing Materials:** Choose fully packed (TFE-Chevron or high temperature Graphite) bonnets, or o-ring seals.
- **Ratings (Metal Seated):**
 - Stainless Steel: 6980 psig @ 100°F (481,2 bar @ 37,8°C); 3525 psig @ 1000°F (243,0 bar @ 537,8°C)
 - Carbon Steel: 6580 psig @ 100°F (453,7 bar @ 37,8°C); 4300 psig @ 650°F (301,3 bar @ 343,3°C)
 - 450°F (232,2°C) limit for Teflon
- **Backseated Bonnets with Packing Below the Stem Threads:** To eliminate potential thread contamination by the process media, the packing is located below the stem threads. Backseating minimizes fugitive emissions with a metal-to-metal backseat that also prevents accidental removal or stem blow-out in operation.
- **Non-Rotating Tip (NRT) Stem:** Provides tight, repeatable shutoff without galling or cross-scoring that occurs on ball type stems. Because the NRT conical stem tip stops rotating when it contacts the seat, further torque turns the stem, but not the tip, protecting the stem tip from damage.

Repeated closures improve the mating between the seat and the stem tip, unlike wear that will occur over time with a ball stem tip.

Flow Schematic



Dimensions

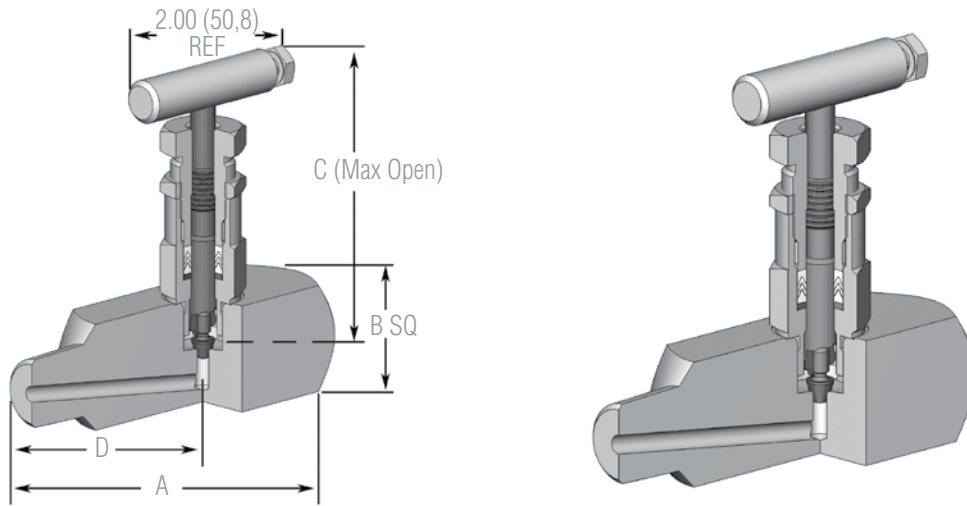

Dimensions – HN491 Hard Seat

Inlet x Outlet	Dimensions, inches (mm)				Weight lbs (kgs)	Orifice inches (mm)
	A	B	C	D		
1/4" (DN8) M x 1/4" (DN8) F	2.50 (64)	1.25 (32)	3.39 (86)	1.50 (38)	1.25 (0,57)	0.19 (5)
1/4" (DN8) F x 1/4" (DN8) F	2.00 (51)	1.25 (32)	3.39 (86)	1.13 (29)	1.25 (0,57)	0.19 (5)
1/2" (DN15) M x 1/2" (DN15) F	3.25 (83)	1.25 (32)	3.52 (89)	1.75 (45)	1.25 (0,57)	0.19 (5)
1/2" (DN15) F x 1/2" (DN15) F	3.25 (83)	1.25 (32)	3.52 (89)	1.75 (45)	1.25 (0,57)	0.19 (5)
1/2" (DN15) TN x 1/2" (DN15) TN	3.00 (76)	1.25 (32)	3.52 (89)	1.58 (40)	1.25 (0,57)	0.19 (5)
3/4" (DN20) M x 3/4" (DN20) F	3.00 (76)	1.50 (38)	3.77 (96)	1.56 (40)	1.75 (0,79)	0.19 (5)
3/4" (DN20) F x 3/4" (DN20) F	3.00 (76)	1.75 (45)	3.77 (96)	1.50 (38)	1.75 (0,79)	0.19 (5)
1" (DN25) M x 1" (DN25) F	4.00 (102)	2.00 (51)	4.02 (102)	2.25 (57)	4.30 (1,95)	0.19 (5)
1" (DN25) F x 1" (DN25) F	3.50 (89)	2.00 (51)	4.02 (102)	1.75 (45)	3.50 (1,59)	0.19 (5)

Pressure and Temperature Chart

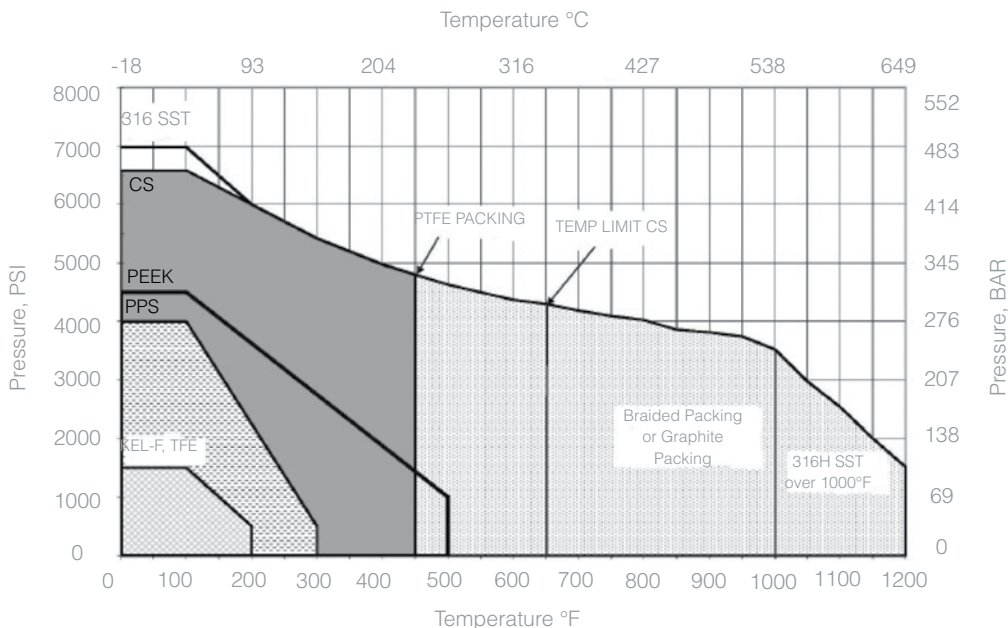

How to Order									
Model Number	Seat	Body Material**	Inlet Size†	Inlet Type‡	Outlet Size†	Outlet Type‡	Stem / Tip Material	Seat Material	Packing
HN49 = Std	1 = Hard	S = Carbon Steel	1 = 1/4" (DN8)	1 = MNPT	1 = 1/4" (DN8)	1 = FNPT	1 = 316 SS NACE	1 = Integral (Hard)	2 = TFE-Chevron
	2 = Soft	U = Stainless Steel	2 = 3/8" (DN10)	2 = MSW	2 = 3/8" (DN10)	2 = FSW	2 = 316 SS Needle / Plug	3 = Stellite Insert	3 = Grafoil / Grafoil / Graphite
	F = Hard / O-Ring	C = Carbon Steel, NACE	3 = 1/2" (DN15)	3 = FNPT	3 = 1/2" (DN15)	8 = Tube Nut	3 = 316 SS / 316 SS NACE	4 = PPS (Soft)	6 = Viton O-Ring
	G = Soft / O-Ring	D = Stainless Steel, NACE	4 = 3/4" (DN20)	4 = FSW	4 = 3/4" (DN20)	R = 1 Plug	4 = 316 SS NRT	5 = KEL-F (Soft)	
	Q = 3/8" (DN10) Orifice Soft Seat	M = Monel	5 = 1" (DN25)	A = Tube Nut	5 = 1" (DN25)	W = TSW	5 = 316 SS / Stellite	6 = TFE (Soft)	
	T = 3/8" (DN10) Orifice Hard Seat	G = Hastelloy B	A = 1/2" (DN15) single ferrule integral tube nut	E = TSW	A = 1/2" (DN15) single ferrule integral tube nut	Z = Non-Standard	A = Monel	9 = PEEK (Soft)	
	V = 11mm Hard Seat	H = Hastelloy C	B = 1/2" (DN15) double ferrule integral tube nut	Z = Non-Standard	B = 1/2" (DN15) double ferrule integral tube nut		B = Monel / Monel		
	W = 16 mm Hard Seat	X = Alloy 20	Z = Non-Standard		Z = Non-Standard		N = Hastelloy C		
							D = Hastelloy C / Hastelloy C		
							G = Alloy 20		
							H = Alloy 20		

** Other materials available upon request.

† Metric sizes available, consult factory.

‡ Other types available upon request.

Sample Ordering Schematic

HN49	1	U	3	1	3	1	4	1	2
------	---	---	---	---	---	---	---	---	---

The 10,000# bonnet assembly was added to the Hex product line to meet the very high pressure requirements in oil and gas production, specifically on offshore drilling platforms.

The 10,000# bonnet assembly is used on our HN49 Series Instrument Valves and can be rated at 10,000 psig @ 100°F (689,5 bar @ 37,8°C) or 6900 psig @ 450°F (475,7 bar @ 232,2°C).

Note that the bonnet is only available with Teflon packing.

Applications

- Shut off applications for most fluids including steam
- Compressors
- Hydraulic and Pneumatic Applications
- Calibration and Testing
- Instrument Isolation and Venting

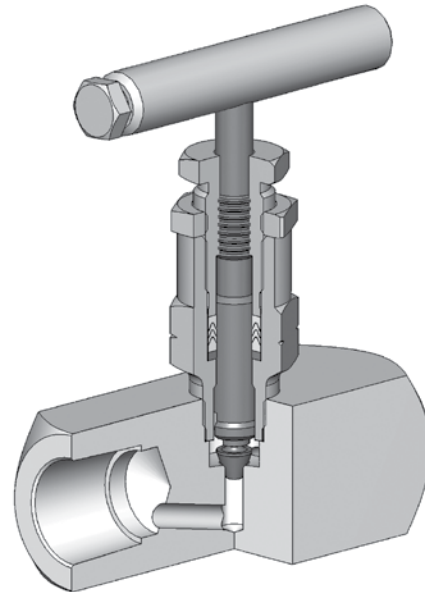

How to Order									
Model Number	Seat	Body Material**	Inlet Size†	Inlet Type‡	Outlet Size†	Outlet Type‡	Stem / Tip Material	Seat Material	Packing
HN49 = 10,000 Designator	0 = 10,000 Bonnet	S = Carbon Steel (A108)	1 = 1/4" (DN8)	1 = MNPT	1 = 1/4" (DN8)	1 = FNPT	1 = 316 SS NACE*	1 = Integral (Hard)	2 = TFE-Chevron
		U = Stainless Steel (SA-479; 316)	2 = 3/8" (DN10)	2 = MSW	2 = 3/8" (DN10)	2 = FSW	3 = 316 SS / 316 SS NACE		
		C = Carbon Steel, NACE	3 = 1/2" (DN15)	3 = FNPT	3 = 1/2" (DN15)	8 = Tube Nut	4 = 316 SS NRT		
		D = Stainless Steel, NACE	4 = 3/4" (DN20)	4 = FSW	4 = 3/4" (DN20)	R = 1 Plug	5 = 316 SS / Stellite		
		M = Monel	5 = 1" (DN25)	A = Tube Nut	5 = 1" (DN25)	W = TSW	A = Monel		
		G = Hastelloy B	A = 1/2" (DN15) single ferrule integral tube nut	E = TSW	A = 1/2" (DN15) single ferrule integral tube nut	Z = Non-Standard	B = Monel / Monel		
		H = Hastelloy C	B = 1/2" (DN15) double ferrule integral tube nut	Z = Non-Standard	B = 1/2" (DN15) double ferrule integral tube nut		N = Hastelloy C		
		X = Alloy 20	Z = Non-Standard		Z = Non-Standard		D = Hastelloy C / Hastelloy C		
							G = Alloy 20		
							H = Alloy 20		

** Other materials available upon request.

† Metric sizes available, consult factory.

‡ Other types available upon request.

Sample Ordering Schematic

HN49	0	U	3	3	3	1	2	1	2
------	---	---	---	---	---	---	---	---	---