

Instrument Grade Ball Valves are primarily used as a block valve for instruments, drain valves, on/off valves for panel and systems, and many other applications and OEM equipment. This cost effective line of ball valves offer several pressure ratings, end connection options (upon request) and sizes.

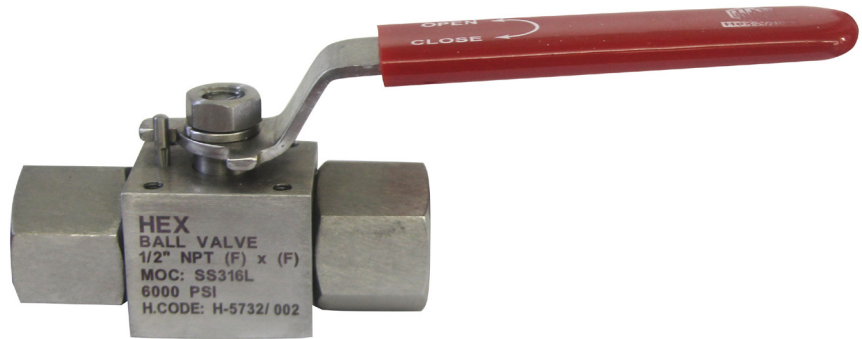

Specifications

- Size: 1/4", 3/8", 1/2", 3/4", 1"
- End Connections: NPT (Male & Female)
- Body Style: 3 piece body
- Body Material: 316SS
- Seat Material: PTFE standard
- Packing: Delrin standard
- Handle: Stainless Steel with cover
- Panel Mount Standard

Options

- Cleaned for oxygen service
- NACE-MR-01-75
- Additional end connections available upon request

Pressure Ratings at room temperature

- 3000 psi
- 6000 psi
- 10,000 psi

Industry Standards and Testing

- ANSI
- ASME

Dimensions - 2 piece design

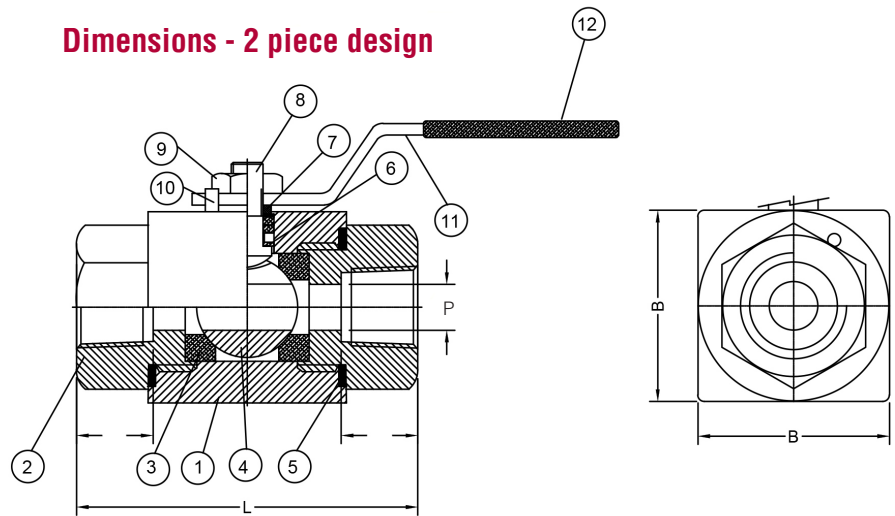

Part No.	Part Description	Material	Qty
1	Body	SS 316L	1
2	Adaptor	SS 316L	2
3	Seat Ring	Delrin	2
4	Ball	SS 316L	1
5	Gasket	PTFE	2
6	Gland Seal	PTFE	2
7	Gland Bush	SS 316L	1
8	Stem	SS 316L	1
9	Lock Nut	SS 304	1
10	Stopper Pin	SS 304	3
11	Handle	S.S.	1
12	Handle Sleeve	P.V.C.	1
P	L +2.0	B +2.0	
1/2" NPT (F)	83.0	32.0	

How to Order

Model Number	Inlet Size	Inlet Type	Outlet Size	Outlet Type	Pressure
IBV	1 = 1/4"	1 = FNPT	1 = 1/4"	1 = FNPT	3K = 3000 psi
	2 = 3/8"		2 = 3/8"		6K = 6000 psi
	3 = 1/2"		3 = 1/2"		10K = 10000 psi
	4 = 3/4"		4 = 3/4"		
	5 = 1"		5 = 1"		
	6 = 1-1/2"		6 = 1-1/2"		

Standard body material is 316SS