



# PRODUCT OVERVIEW



## ABOUT HEX VALVE

Hex Valves were developed to simplify the piping required throughout the process industries. These valves are so common, "Hex Valve" became a generic term for bar stock instrument, gauge, and orifice valves. Today, leaders in the natural gas, chemical and petroleum industries depend on Hex Valve for reliable equipment that is easy to install and operate.

Testing to EPA Reference Method 21 (reference: 40 CFR 60, BAAQMD, Reg. 8, Rule 18, SCAQMD rules), all Hex Valve TFE, 1625G Grafoil and Graphaseal bonnet valves are Certified Low E, guaranteed not to leak more than 100ppm for five (5) years in accordance with industry mandates.

Hex Valve adds value for customers by manufacturing products that are reliable and durable which will help you avoid costly shutdowns and production delays. Hex Valve pays close attention to every detail of design, manufacturing and assembly of each component. Hex Valve can help you with all of your instrumentation products including manifold, needle, block & bleed, gauge, mono-weld and mono-flange valves.

Contact us today at [hex@richardsind.com](mailto:hex@richardsind.com) or +1.513.533.5600.

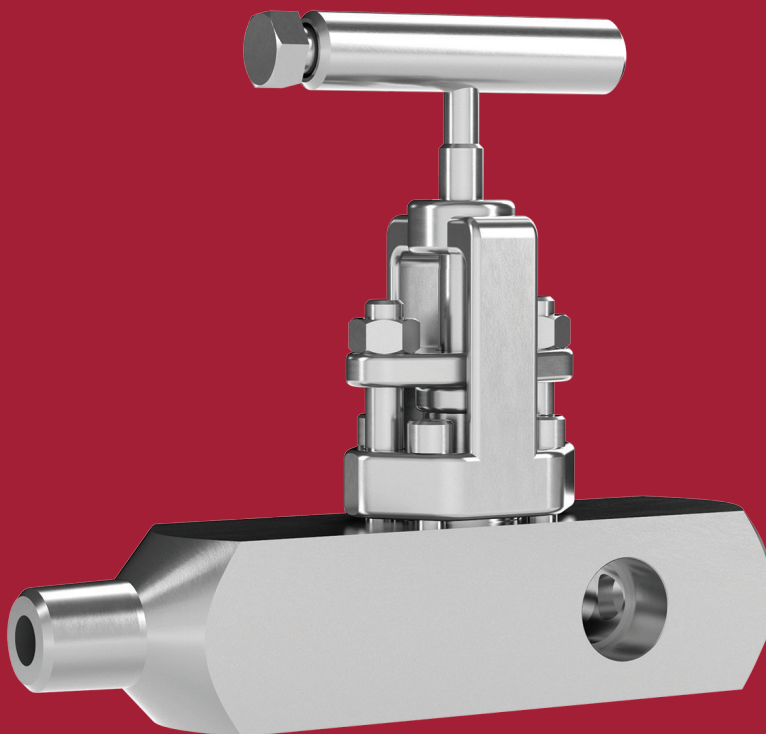

# TABLE OF CONTENTS

	Needle Valves	4
	Primary Gauge Valves	6
	Block & Bleed Valves	9
	Hexblok/Monoflange/Weld/Ball Valves	11
	Two Valve Manifolds	14
	Three Valve Manifolds	15
	Five Valve Manifolds	18
	Natural Gas Valves	19
	Power Valves	20
	Special Valves	24

# NEEDLE VALVES

## HN29

### Instrument "Mini" Needle Valves

Targeted for the gas sampling, OEM and reseller market. "T" handles or 25,4mm diameter round knurled handles

Sizes	1/4" & 1/2"
Ratings	Stainless and carbon steel valves are rated to 414 bar @ 38°C with hard seats & 207 bar @ 38°C with soft seats (Delrin for carbon steel).
Features	Non-rotating tip provides tight repeatable shutoff without galling or cross scoring; saves space and reduces costs



## HN39

### Stainless Steel Instrument Needle Valves

A compact and economical high pressure instrument block valve. All valves have integral hard seats, 316 stainless steel body and trim and Teflon/Grafoil packing.

Sizes	1/8", 1/4", 3/8", 1/2", 3/4", 1", 6mm, 8mm, 10mm, 14mm, 18mm, 25mm
Ratings	Stainless steel to 481 bar @ 38°C. 232°C limit for Teflon packed valves. 538°C limit for Grafoil packed valves.
Features	Non-rotating tip provides tight repeatable shutoff without galling or cross scoring; integral body & bonnet design

## EN39

### Economical Needle Valves

All valves are available with integral hard seats, 316-NACE stainless steel body and trim and Teflon or Graphite packing. Hastelloy C and Monel available upon request.

Sizes	1/4" & 1/2"
Ratings	Stainless steel with TFE packing: 414 bar @ 38°C; 290 bar @ 204°C
Features	Non-rotating tip provides tight repeatable shutoff without galling or cross scoring; compact & economical





## HN41

### Roddable Instrument Needle Valves

A straight-thru design with Delrin seat which provides bi-directional flow and the ability to "rod-out" the valve for cleaning. Specifically targeted for oil & gas industry.

Sizes	1/4" & 1/2"
Ratings	414 bar @ 38°C
Features	Roddable design; rising plug design for better shutoff; thread in bonnet above packing; larger handle and stem diameter

## HN49

### Instrument Needle Valves

A heavy duty needle valve that features an industrial strength stem and bonnet and enhanced packing arrangement, all designed to handle the tough conditions of high pressure and high temperature services.

Sizes	1/8", 1/4", 3/8", 1/2", 3/4", 1", 6mm, 8mm, 10mm, 14mm, 18mm, 25mm
Ratings	481 bar @ 38°C; 243 bar @ 538°C (stainless steel); 454 bar @ 38°C; 296 bar @ 343°C (carbon steel) 232°C limit for Teflon
Features	Wide selection of body/bonnet and packing materials; non-rotating stem; backseated bonnets with packing below the stem threads

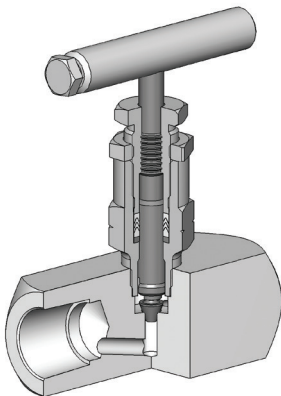

## HN490

### 10,000# Instrument Needle Valves

The 10,000# bonnet assembly was added to meet the very high pressure requirements in oil & gas production, specifically on offshore drilling platforms.

Sizes	1/4", 3/8", 1/2", 3/4", 1"
Ratings	689 bar @ 38°C or 476 bar @ 232°C. Bonnet is only available with Teflon packing
Applications	Shut off for most fluids including steam; compressors; hydraulic and pneumatic applications; calibration & testing

## HN49U

### Union Bonnet Needle Valves

Severe service union-bonnet needle valve that features a one-piece forged body and grafoil packing designed to handle the extreme conditions of high pressure and temperature services.

Sizes	6mm & 10mm orifice sizes
Ratings	689 bar @ 38°C; 241 bar @ 649°C
Features	Backseated bonnets with packing below the stem threads; panel mounting standard; non-rotating ball tip stem provides for repeatable, leak-tight shutoff



# PRIMARY GAUGE VALVES

## HG35

### Gauge Valves

Meets the application requirement for a block & bleed valve without the need for a close nipple when connecting to a female port on a gauge pressure transmitter.

Sizes	1/4", 3/8", 1/2", 3/4", 1"
Ratings	481 bar @ 38°C; 243 bar @ 538°C (Stainless Steel with graphite packing); 232°C limit for Teflon
Features	Threads in the bonnet are above the stem packing to eliminate possible thread contamination; non-rotating tip provides tight repeatable shutoff; save money by reducing the number of components; reduces number of leak points

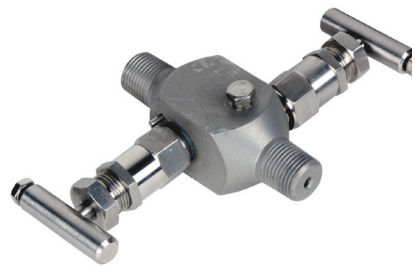

## EG35

### Economical Gauge Valves

Meets the application requirement for a block & bleed valve without the need for a close nipple when connecting to a female port on a gauge pressure transmitter.



Sizes	1/2" & 3/4"
Ratings	Stainless steel with TFE packing: 414 bar @ 38°C; 290 bar @ 204°C
Features	Valves available with integral hard seats, 316-NACE stainless steel body and trim and Teflon or Graphite packing

## HG46

### Gauge Valves

A quick, inexpensive and compact means of installing gauges and static pressure instrumentation. Can be supplied with a bleed valve or needle valve threaded into one of the outlets to allow for combined block & bleed functions in a single, compact unit.

Sizes	1/4", 3/8", 1/2", 3/4", 1"
Ratings	481 bar @ 38°C; 243 bar @ 538°C (Stainless Steel with graphite packing); 232°C limit for Teflon
Features	Compact design; non-rotating tip; OS&Y bonnet for added safety; packing below the threads prevents lubricant wash out and corrosion

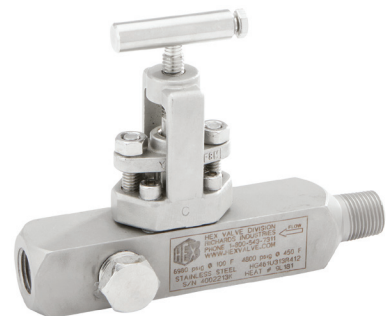

## HG47

### Gauge Valves

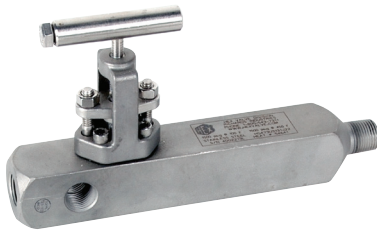

A roddable, hard seated orifice valve. Ideal for use on high temperature, viscous service. Provides full port, unrestricted flow.

Sizes	1/4", 3/8", 1/2", 3/4", 1"
Ratings	481 bar @ 38°C; 243 bar @ 538°C (Stainless Steel with graphite packing); 232°C limit for Teflon
Features	Cost savings by reducing number of components and leak points; compact design, Non-rotating tip; packing below the threads prevents lubricant washout and corrosion.

## HG48

### Gauge Valves

Provides three outlet connections to facilitate the mounting of gauges and other static pressure instruments in a variety of positions.

Sizes	1/4", 3/8", 1/2", 3/4", 1"
Ratings	481 bar @ 38°C; 243 bar @ 538°C (Stainless Steel with graphite packing); 232°C limit for Teflon
Features	Cost savings by reducing number of components and leak point; compact design; non-rotating tip; packing below threads prevents lubricant wash out and corrosion



## EG48

### Economical Gauge Valves

Provides three outlet connections to facilitate the mounting of gauges and other gauge pressure instruments in a variety of positions. Integral hard seat matches body material.

Sizes	1/2" & 3/4"
Ratings	SS with TFE packing & hard seat: 414 bar @ 38°C; 290 bar @ 204°C
Features	All valves are available with integral hard seats; 316-NACE stainless steel body & trim; Teflon or Graphite packing

## HG65

### Orifice Block Valves

Designed for compact side-by-side mounting on standard orifice flanges, condensate chambers, mercury traps and seal traps. Two outlet ports are provided for impulse line connections or for pressure mounting.

Sizes	1/4", 3/8", 1/2", 3/4", 1"
Ratings	481 bar @ 38°C; 243 bar @ 538°C (Stainless Steel with graphite packing); 232°C limit for Teflon
Features	Ideal for light hydrocarbons or utility service; non-rotating tip stem; VOC emission compliance; reduce cost & installation time





## EG65

### Economical Orifice Block Valves

Designed for compact side-by-side mounting on standard orifice flanges, condensate chambers, mercury traps and seal traps. Two outlet ports are provided for impulse line connections or for pressure mounting.

Sizes	1/2" & 3/4"
Ratings	414 bar @ 38°C; 209 bar @ 538°C (Stainless Steel with graphite packing); 204°C limit for Teflon
Features:	Ideal for light hydrocarbons or utility service; reduce cost & installation time

## HG12

### Orifice Block Valves

The valve features a built-in vent or bleed screw on the outlet side of the valve. In process line mounted instrument or signal line tubing, venting or line-filling capabilities can be added.

Sizes	1/4", 3/8", 1/2", 3/4", 1"
Ratings	481 bar @ 38°C; 243 bar @ 538°C (Stainless Steel with graphite packing); 232°C limit for Teflon
Features:	Compact, side-by-side mounting; reduce potential leakage; non-rotating tip stem; reduce cost & installation time



## H025

### Orifice Block Valves

Features an OS&Y bolted bonnet and two outlet connections. The H025 is more compact and has a shorter profile than the HG65 model to reduce vibration.

Sizes	1/4", 3/8", 1/2", 3/4", 1"
Ratings	481 bar @ 38°C; 243 bar @ 538°C (Stainless Steel with graphite packing); 232°C limit for Teflon
Features	Compact, side-by-side mounting; reduce potential leakage; non-rotating tip stem; reduce cost & installation time



# BLOCK & BLEED VALVES

## HB50/51

### Block & Bleed Valves

A fully packed and backseated block valve along with a bleed valve with directional discharge tube and stem stop. The HB50 can provide secondary block & bleed functions on multiple instrument installations. The HB51 utilizes a bleed screw in lieu of a bleed valve.

Sizes	1/4", 3/8", 1/2", 3/4", 1"
Ratings	481 bar @ 32°C; 243 bar @ 538°C (Stainless Steel with graphite packing); 232°C limit for Teflon
Features	Cost savings; compact design features 2 valves in 1 to utilize less space; non-rotating tip; packing below threads



HB50 Series shown



## EB50

### Economical Block & Bleed Valves

A fully packed and backseated block valve along with a bleed/plug. With a gauge or transmitter threaded in its outlet, it will allow pressure to be blocked and bled for convenient instrument removal. It can also provide secondary block & bleed functions.

Sizes	1/2"
Ratings	414 bar @ 38°C; 290 bar @ 204°C (Stainless Steel with Teflon packing)
Features	Cost savings; compact design features 2 valves in 1 to utilize less space

## HB52

### Bleed Tee Valves

Ideal for modernizing outdated, non-bleed gauge installations. During instrument maintenance, simply thread it into the outlet of an existing block valve. An instrument is then threaded into the HB52 outlet to complete the installation.

Sizes	1/4", 3/8", 1/2", 3/4", 1"
Ratings	481 bar @ 38°C; 243 bar @ 538°C (Stainless Steel)
Features	Cost savings by reducing number of components and leak points; compact design features 2 valves in 1 to utilize less space



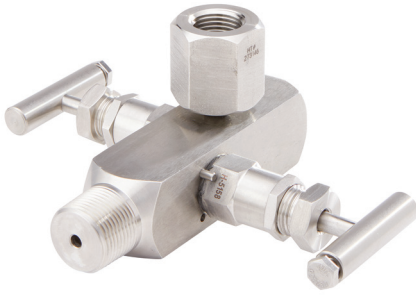

# HB59

## Integral Block & Bleed Valves

A fully packed backseated block and bleed valve that minimizes threaded connections. Typically used on applications where waste must be returned to the line or holding vessel.

Sizes	1/4", 3/8", 1/2", 3/4", 1"
Ratings	481 bar @ 38°C; 243 bar @ 538°C (Stainless Steel with graphite packing); 232°C limit for Teflon
Features	Cost savings; compact design; non-rotating tip; packing below the threads prevents lubricant washout and corrosion

# HB24/25/26/27

## Block & Bleed Valves

Available individually or optionally threaded into an unused outlet port on a variety of models. Used for bleeding off high pressure media.

Sizes	1/4", 3/8", 1/2", 3/4"
Ratings	481 bar @ 38°C; 243 bar @ 538°C (Stainless steel)
Features	Reduce costs and installation time



# HG35

## Block & Bleed Valves

Meets the application requirement for a block & bleed valve without the need for a close nipple when connecting to a female port on a gauge pressure transmitter.



Sizes	1/4", 3/8", 1/2", 3/4", 1"
Ratings	481 bar @ 38°C; 243 bar @ 1000°F (Stainless Steel with graphite packing); 232°C limit for Teflon
Features	Threads in the bonnet are above the stem packing to eliminate possible thread contamination; non-rotating tip provides tight repeatable shutoff; save money by reducing the number of components; reduces number of leak points

# EG35

## Economical Block & Bleed Valves

Meets the application requirement for a block & bleed valve without the need for a close nipple when connecting to a female port on a gauge pressure transmitter.

Sizes	1/2" & 3/4"
Ratings	Stainless steel with TFE packing: 414 bar @ 38°C; 290 bar @ 204°C
Features	Valves available with integral hard seats, 316-NACE stainless steel body and trim and Teflon or Graphite packing



# HEXBLOK VALVES

## HEXBLOK

### Ball Valves

Used primarily on upstream offshore/onshore oil production and initial processing installations. Typically used on liquid hydrocarbon applications to minimize the size and weight of the pipe-valve assemblies associated with gauge pressure or analytical instrumentation.

Sizes	1/2" - 2"
Ratings	In accordance to ASME B16.5 for class 150 to 2500 up to 6000psi. Working temperatures up to 232°C for Teflon & Graphite packing and PEEK seals
Features	Compact; rigid; lighter; safer; lower cost than conventional piping methods; reduced link points; pressure point closer to pressure measurement



## HEXBLOK

### Needle Valves

Used primarily on upstream offshore/onshore oil production and initial processing installations. Typically used on liquid hydrocarbon applications to minimize the size and weight of the pipe-valve assemblies associated with gauge pressure or analytical instrumentation.

Sizes	1/2" - 2"; 10mm Bore/Orifice sizes
Ratings	In accordance to ASME B16.5 for class 150 to 2500 232°C for Teflon packing; 538°C for Graphite packing
Features	Large standard orifice and porting; large, robust bonnet and NRT stem design means longer life, less breakage; non-rotating stem tip

# MONOFLANGE VALVES

## MONOFLANGE

### Monoflange Valves

Applications: pressure instrument take-off points, sampling systems, chemical injection systems, hydraulic power units, high pressure fire safe valves, drains for tanks and pipes where space is limited.

Sizes	Flange in accordance to ASME B16.5
Ratings	Class 150 to 2500. Working Temperatures up to 538°C
Features	Compact; rigid; lighter; safer; lower cost than conventional piping methods; reduced link points; pressure point closer to pressure measurement



# MONOWELD VALVES

## MONOWELD

### Monoweld Valves

Used on upstream offshore/onshore gas & oil production and initial processing installations. Typically used on single or dual gauge pressure or analyzer installations to minimize the size & weight of the pipe-valve assemblies.

Sizes	1/4", 3/8", 1/2", 3/4", 1"
Ratings	In accordance to ASME B16.5 for class 150 to 2500 232°C for Teflon packing; 538°C for Graphite packing
Features	Integral Weldolet® means one weld instead of two per gauge pressure or analyzer take off, reduces total installation height and weight

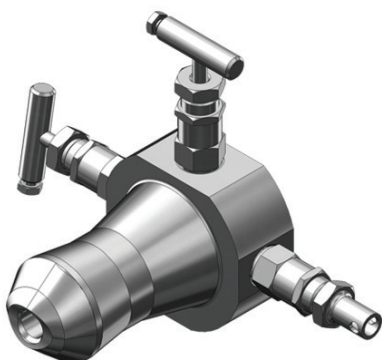

# MONOBALL VALVES

## MONOBALL

### Monoball Valves

Designed for direct shutoff of flow like any ball valve. The difference is the compact design and light weight. It can be used in conjunction with other valves to allow for a safer shutoff creating a double block for safety.

Sizes	1/2" - 2"
Ratings	ANSI B16.34 flange ratings for Class 150 - 2500# flanges 689 bar @ 38°C with Carbon PEEK Seats or 431 bar @ 38°C with standard PEEK Seats
Features	Small, thin design and lightweight; design allows you to combine with other valves in series for safe shutoff; 10mm through bore; API 607 5th Edition Fire Safe

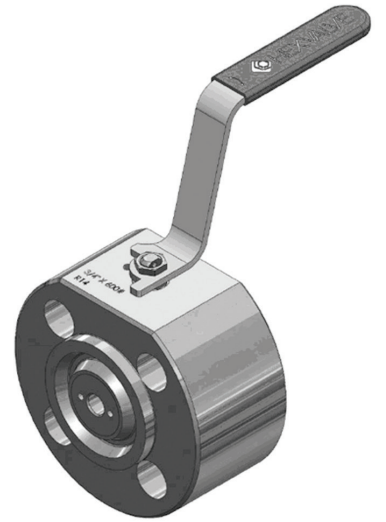

# TWO VALVE MANIFOLD VALVES

## HM50

### Static Pressure Manifold Valves

A single flanged static pressure manifold that includes a primary block valve, a secondary shutoff valve and a bleed valve into a single valve assembly. The secondary shutoff and bleed valve allows the gauge and transmitter to be vented and/or removed.

Sizes	1/2" x Instrument Flange
Ratings	481 bar @ 38°C; 243 bar @ 538°C (Stainless Steel with graphite packing); 232°C limit for Teflon
Features	Reduce costs and installation time; non-rotating tip stem; fully backseated bonnets

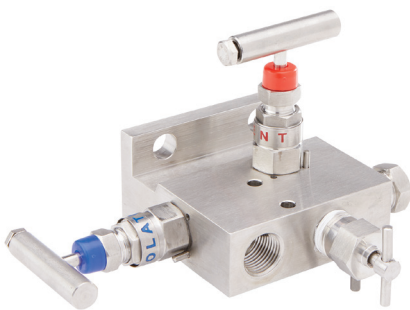
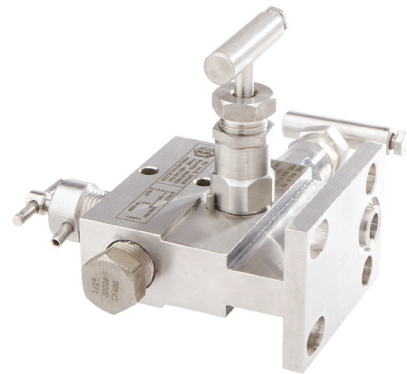

## EM50

### Economical Static Pressure Manifold Valves

A single flanged, static pressure manifold that incorporates a block valve and a vent valve into a single valve assembly. The side vent outlet is plugged, allowing removal during maintenance or the installation of a calibration fitting.

Sizes	1/2" x Instrument Flange
Ratings	414 bar @ 38°C; 290 bar @ 204°C (Stainless Steel with TFE packing)
Features	Compact & economical

## HM59

### Static Pressure Manifold Valves

A line-mounted two valve manifold that functions as a shutoff and vent valve for static pressure instrumentation. Provides separate instrument bleed and a calibration entry port to allow for fast, accessible zeroing and calibration of gauge pressure transmitters.

Sizes	1/4", 1/2", 3/4", 1"
Ratings	Stainless Steel: 481 bar @ 38°C & 243 bar @ 538°C Carbon Steel: 454 bar @ 38°C & 296 bar @ 343°C
Features	Low cost; easy to install; non-rotating tip stem; fully backseated bonnets

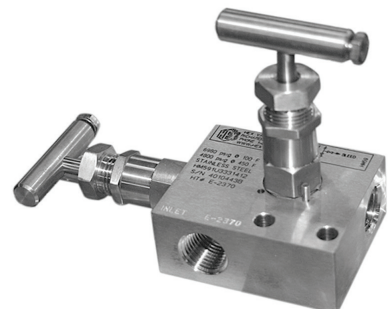



## EM59

### Economical Gauge Pressure Manifold Valves

A compact remote two valve manifold that functions as a shutoff and vent valve for static pressure instrumentation. It reduces the number of threaded connections, resulting in fewer potential leak points.

Sizes	1/2"
Ratings	414 bar @ 38°C; 290 bar @ 204°C (Stainless Steel with TFE packing)
Features	Easy to install; less material and labor costs

## HM58

### Level Manifold Valves

Simplified, lower cost alternatives to traditional manifolds used in D/P level installations. Eliminates the need for tubing, fittings, instrument pipe stands and their associated installation costs.

Sizes	1/2", 1", 1-1/2", 2", 3", 4"
Ratings	481 bar @ 38°C; 243 bar @ 538°C (Stainless Steel with graphite packing); 232°C limit for Teflon
Features	Can be used for vented or closed tank, bottom or side-mounted installations or for tank top mounted bubbler installations.

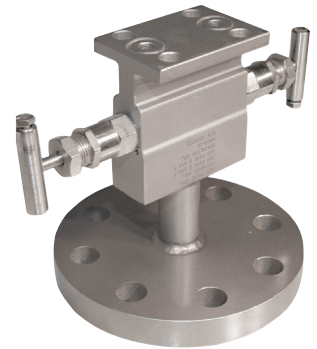

# THREE VALVE MANIFOLD VALVES

## HM45

### In-line Manifold Valves

A general purpose instrument manifold designed for connecting differential pressure transmitters to impulse line tubing. Connectors are 1/2" NPT on industry standard 2-1/8" center-to-center dimensions).

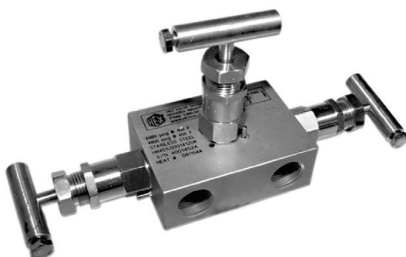

Sizes	1/4", 3/8", 1/2", 3/4", 1"
Ratings	481 bar @ 38°C; 243 bar @ 538°C (Stainless Steel with graphite packing); 232°C limit for Teflon
Features	VOC emission compliance; non-rotating tip stem; minimum emission flange; removable bracket option



# EM45

## In-line Manifold Valves

A general purpose instrument manifold designed for connecting differential pressure transmitters or flow recorders to impulse line tubing.

Sizes	1/2"
Ratings	414 bar @ 38°C; 290 bar @ 204°C (Stainless Steel with TFE packing)
Features	Available with integral hard seats; 316-NACE Stainless Steel body & trim and Teflon or Graphite Packing

# HM46

## In-line Manifold Valves with Vent

The same design as the HM45 but also incorporating a vent valve allowing a technician to perform instrument bleed or blowdown procedures

Sizes	1/4", 3/8", 1/2", 3/4", 1"
Ratings	481 bar @ 38°C; 243 bar @ 538°C (Stainless Steel with graphite packing); 232°C limit for Teflon
Features	VOC emission compliance; non-rotating tip stem; minimum emission flange; removable bracket option

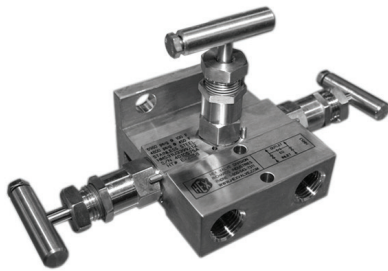
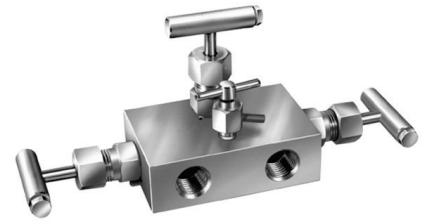

# HM53

## Single Flanged Manifolds

Used to perform the block, equalizing and vent requirements of differential pressure transmitter applications. The single mounting flange allows the transmitter to bolt directly to the manifold, eliminating the piping of excess tubing and nipples.

Sizes	1/2" x Instrument Flange
Ratings	481 bar @ 38°C; 243 bar @ 538°C (Stainless Steel with graphite packing); 232°C limit for Teflon
Features	VOC emission compliance; non-rotating tip stem; minimum emission flange; removable bracket option

# EM53

## Economical Single Flanged Manifolds

Used to perform the block, equalizing and vent requirements of differential pressure transmitter applications. Has a single mounting flange allowing the transmitter to bolt directly to the manifold.

Sizes	1/2" x Instrument Flange
Ratings	414 bar @ 38°C; 290 bar @ 204°C (Stainless Steel with TFE packing)
Features	Available with integral hard seats; 316-NACE stainless Steel body & trim and Teflon or Graphite Packing





## HM54

### Double Flanged Manifold Valves

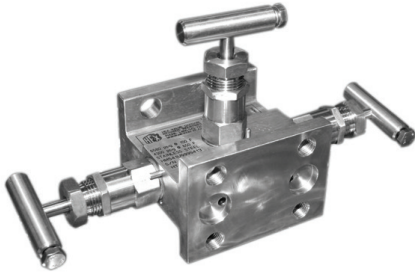

Used to perform the block, equalizing and vent requirements of differential pressure transmitters. The manifold can bolt directly to the instrument and can be mated directly to the orifice flange using futbol flanges and short nipples

Sizes	Instrument Flange x Instrument Flange
Ratings	481 bar @ 38°C; 243 bar @ 538°C (Stainless Steel with graphite packing); 232°C limit for Teflon
Features	VOC emission compliance; non-rotating tip stem; minimum emission flange; removable bracket option

## EM54

### Economical Double Flanged Manifold Valves

Used to perform the block, equalizing and vent requirements of differential pressure transmitters. The manifold can bolt directly to the instrument and can be mated directly to the orifice flange using futbol flanges and short nipples

Sizes	Instrument Flange x Instrument Flange
Ratings	414 bar @ 38°C; 290 bar @ 204°C (Stainless Steel with TFE packing)
Features	VOC emission compliance; minimum emission flange; removable bracket option

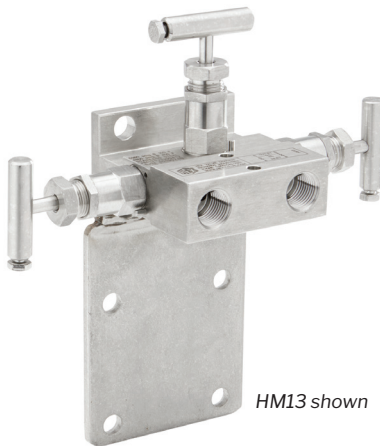

HM13 shown

## HM10/13/14/16/18

### Rigid Mount Manifold Valves

The rigid mount manifolds feature an integral mounting flange, eliminating the extra bolting associated with a transmitter mounting bracket.

Sizes	1/2" x Instrument Flange
Ratings	481 bar @ 38°C; 243 bar @ 538°C (Stainless Steel with graphite packing); 232°C limit for Teflon
Features	Non-rotating tip stem; your choice of mounting options; fully packed bonnets

# FIVE VALVE MANIFOLD VALVES

## HM57

### Manifold Valves

Two shutoff valves, two equalizing valves and a vent/calibration valve in a single, compact assembly. The double equalizing arrangement insures against measurement error that can occur from equalizer leakage between high and low pressure connections.

Sizes	1/2", Flanged
Ratings	481 bar @ 38°C; 243 bar @ 538°C (Stainless Steel with graphite packing); 232°C limit for Teflon
Features	Reduce costs & installation time; integral vent/calibration valve; fewer leak points; your choice of mounting styles

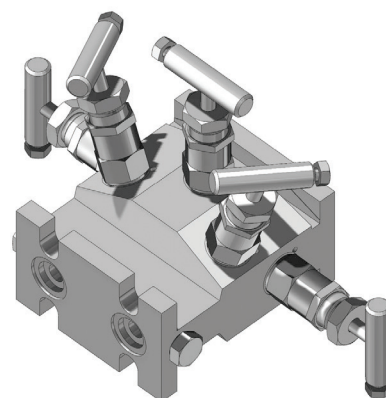

## EM57

### Economical Manifold Valves

Two shutoff valves, two equalizing valves and a vent/calibration valve in a single, compact assembly. The double equalizing arrangement insures against measurement error that can occur from equalizer leakage between high and low pressure connections.

Sizes	1/2", Flanged
Ratings	414 bar @ 38°C; 290 bar @ 204°C (Stainless Steel with TFE packing)
Features	Precise measurement; ideal for custody transfer or other critical flows



## HM37

### Manifold Valves

Two isolation valves, two equalizing valves and a vent/calibration valve in a single, compact assembly. When expensive liquid or gas changes ownership, precise measurement is critical.

Sizes	Flanged
Ratings	207 bar @ 38°C; 103 bar @ 93°C
Features	User friendly design; longer body; mounting taps for universal bracket installation; o-ring bonnets; 2 configurations

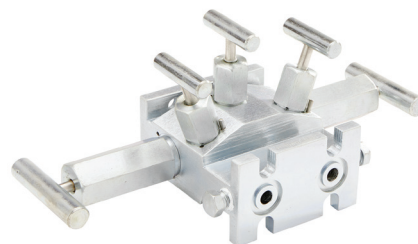

# NATURAL GAS VALVES

## HE30

### Equalizing Valves

A compact and cost effective alternative to the more costly five-valve manifold. Delrin or Teflon soft seat valves insure redundant equalizer isolation, eliminating the possibility of costly leaks there or through the vent/calibrate valve

Sizes	1/4"
Ratings	103 bar @ 38°C; 34 bar @ 93°C
Features	Delrin seats insure tight shutoff; offset vent valve for ergonomic handle operation, non-rotating tip stem

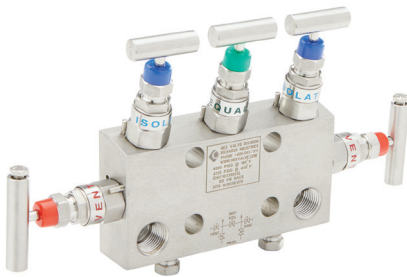
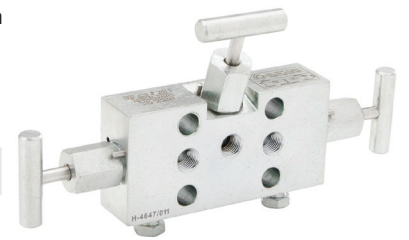

## EH37

### Economical Manifold Valves

Designed for direct mounting to the transmitter with a threaded inlet and instrument flanged outlet. The unique, compact barstock design makes this a good choice when a direct mount manifold with vent and calibration access is crucial

Sizes	1/2"
Ratings	414 bar @ 38°C; 290 bar @ 204°C (Stainless Steel with TFE packing)
Features	Designed for direct mounting to the transmitter with a threaded inlet and instrument flanged outlet. The unique, compact barstock design makes this an economical choice when direct mounted manifold with vent and calibration access is crucial

## HM37

### Manifold Valves

Two isolation valves, two equalizing valves and a vent/calibration valve in a single, compact assembly. When expensive liquid or gas changes ownership, precise measurement is critical.

Sizes	Flanged
Ratings	207 bar @ 38°C; 103 bar @ 93°C
Features	User friendly design; longer body; mounting taps for universal bracket installation; o-ring bonnets; 2 configurations

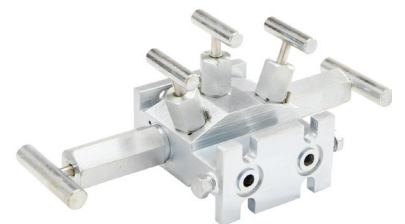

# POWER VALVES

## PM SERIES

### Three & Five Valve Power Manifold Valves

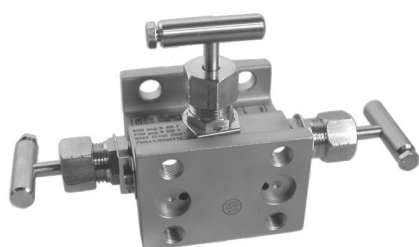

PM54 Series shown

A complete line of three and five valve instrument manifolds for the power industry. For in-line, single flanged for mounting, double flanged for direct mounting and direct mounted compact wafer.

Sizes	1/2", 3/4", Flanged
Ratings	414 bar @ 38°C; 209 bar @ 538°C (Stainless Steel with Graphite Packing)
Features	Conforms to the Power Standards ANSI B31.1 and B31.3 specifications

## PM SERIES

### Two Valve Power Manifold Valves

Available as a primary block valve, bleed valve and secondary shutoff valve into one small unit, or a line-mounted manifold that functions as a shutoff and bleed valve for static pressure instrumentation.

Sizes	1/2", 3/4", Flanged
Ratings	414 bar @ 38°C; 209 bar @ 538°C (Stainless Steel with Graphite Packing)
Features	Conforms to the Power Standards ANSI B31.1 and B31.3 specifications

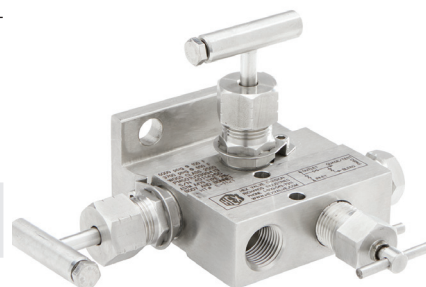

PM50 Series shown

## PM75

### Power Manifold Valves



Designed for remote mounting of differential pressure transmitters. It includes two isolation valves, one test valve and two test/purge valves. The manifold can be mounted via pipe stand or instrument rack.

Sizes	1/2", 3/4", Flanged
Ratings	414 bar @ 38°C; 209 bar @ 538°C (Stainless Steel with Graphite Packing)
Features	Conforms to the Power Standards ANSI B31.1 and B31.3 specifications

## PM76

### Five Valve Power Manifold Valves



Designed for direct mounting to transmitter by unique wafer design. The compact design eliminates the requirement for additional tubing or piping from manifold to transmitter.

Sizes	1/2", 3/4", Flanged
Ratings	6000 psig @ 100°F; 3030 psig @ 1000°F (Stainless Steel with Graphite Packing)
Features	Conforms to the Power Standards ANSI B31.1 and B31.3 specifications

## PM10/13/14/16/18 Rigid Mount Power Manifold Valves

Can mount directly to the pipe stand securing the impulse lines so the transmitter can be installed or removed independently of the piping.

Sizes	1/2", 3/4", Flanged
Ratings	414 bar @ 38°C; 209 bar @ 538°C (Stainless Steel with Graphite Packing)
Features	Conforms to the Power Standards ANSI B31.1 and B31.3 specifications

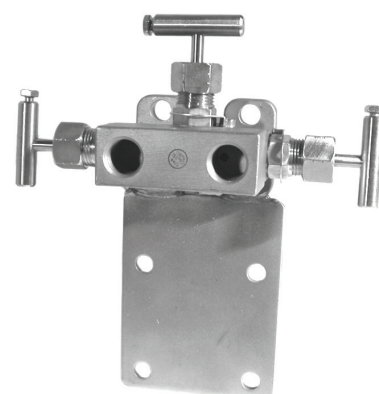

## PG46

### Gauge Power Valves

Provides three outlet connections to facilitate the mounting of gauges and other static pressure instrumentation in a variety of positions. The design results in a compact installation with minimal leak points.

Sizes	1/4", 1/2", 3/4", 1"
Ratings	414 bar @ 38°C; 209 bar @ 538°C (Stainless Steel with Graphite Packing)
Features	Conforms to the Power Standards ANSI B31.1 and B31.3 specifications

## PN49

### Needle Power Valves

A fully packed needle valve for high pressure and high temperature applications. Produced in a wide variety of inlet and outlet sizes.

Sizes	1/4", 1/2", 3/4", 1"
Ratings	414 bar @ 38°C; 209 bar @ 538°C (Stainless Steel with Graphite Packing)
Features	Conforms to the Power Standards ANSI B31.1 and B31.3 specifications

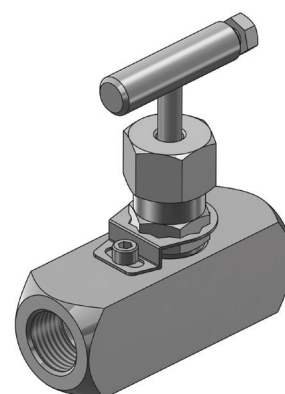



## PB59

### Block & Bleed Power Valves

For critical services, the PB59 block and bleed valve features a fully packed and backseated block valve along with a fully packed integral bleed valve.

Sizes	1/4", 1/2", 3/4", 1"
Ratings	414 bar @ 38°C; 209 bar @ 538°C (Stainless Steel with Graphite Packing)
Features	Conforms to the Power Standards ANSI B31.1 and B31.3 specifications

# SPECIAL VALVES

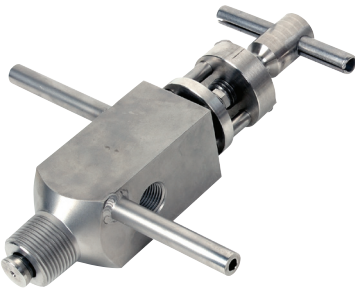

## HS31

### Sample/Drain Valves

A sample/drain valve used to extract a fresh sample while providing tight shutoff and high pressure and temperature capabilities.

Sizes	3/4", 1", 1-1/2"
Ratings	214 bar @ 38°C; 148 bar @ 538°C (Stainless Steel with Graphite Packing)
Features	Wide material selection suits a variety of applications & services; reciprocating stem; dual seating option

## HA

### Air & Gas Distribution Manifolds

A soft seated multi-valve manifold that allows you to connect one air/gas source to the inlet for distribution of up to twelve separate work stations. Used in place of conventional methods for the distribution of plain air and purge gases.

Sizes	1/4", 1/2", 3/4", 1"
Ratings	103 bar @ 38°C; 34 bar @ 93°C
Features	Reduce costs and installation time; reduces potential leakage; integral mounting plates; fully backseated bonnets; anti-tamper handles



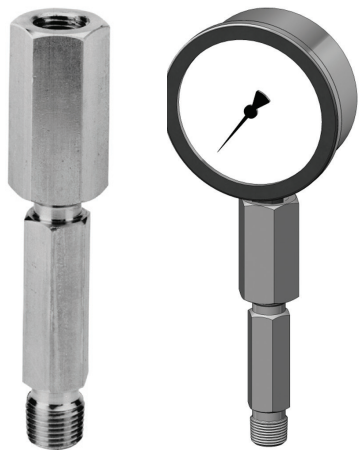

## HGSY/HGVS

### Gauge Syphons

Act as thermal and liquid seal barriers between hot process vapors (such as steam and heat transfer fluids) and the gauge pressure instrument. It provides maximum instrumentation protection in half the space.

Sizes	1/4", 1/2", 3/4", 1"
Ratings	414 bar @ 38°C; 209 bar @ 538°C (Stainless Steel with graphite packing, if applicable)
Features	Minimizes space/radius requirements; minimizes deflection stress; thermal protection; leak point minimization



3170 Wasson Rd. Cincinnati, OH 45209  
P: +1.513.533.5600 • F: +1.513.871.0105  
[www.hexvalve.com](http://www.hexvalve.com)  
[hex@richardsind.com](mailto:hex@richardsind.com)