



PRODUCT OVERVIEW



ABOUT HEX VALVE

Hex Valves were developed to simplify the piping required throughout the process industries. These valves are so common, "Hex Valve" became a generic term for bar stock instrument, gauge, and orifice valves. Today, leaders in the natural gas, chemical and petroleum industries depend on Hex Valve for reliable equipment that is easy to install and operate.

Testing to EPA Reference Method 21 (reference: 40 CFR 60, BAAQMD, Reg. 8, Rule 18, SCAQMD rules), all Hex Valve TFE, 1625G Grafoil and Graphaseal bonnet valves are Certified Low E, guaranteed not to leak more than 100ppm for five (5) years in accordance with industry mandates.

Hex Valve adds value for customers by manufacturing products that are reliable and durable which will help you avoid costly shutdowns and production delays. Hex Valve pays close attention to every detail of design, manufacturing and assembly of each component. Hex Valve can help you with all of your instrumentation products including manifold, needle, block & bleed, gauge, mono-weld and mono-flange valves.

Contact us today at hex@richardsind.com or 513.533.5600.

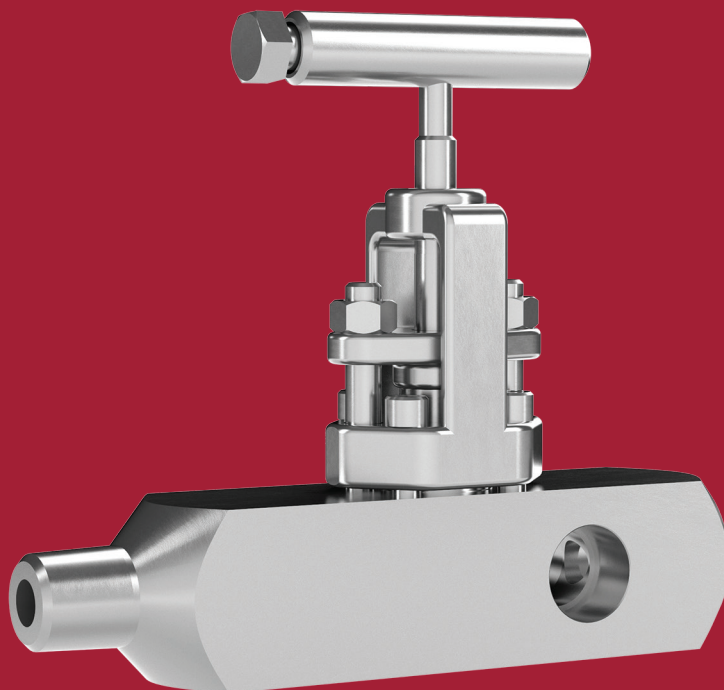











TABLE OF CONTENTS

| | | |
|---|-------------------------------------|----|
|  | Needle Valves | 4 |
|  | Primary Gauge Valves | 6 |
|  | Block & Bleed Valves | 9 |
|  | Hexblok/Monoflange/Weld/Ball Valves | 11 |
|  | Two Valve Manifolds | 14 |
|  | Three Valve Manifolds | 15 |
|  | Five Valve Manifolds | 18 |
|  | Natural Gas Valves | 19 |
|  | Power Valves | 20 |
|  | Special Valves | 24 |

NEEDLE VALVES

HN29

Instrument "Mini" Needle Valves

Targeted for the gas sampling, OEM and reseller market. "T" handles or 1" diameter round knurled handles

| | |
|----------|---|
| Sizes | 1/4" & 1/2" |
| Ratings | Stainless and carbon steel valves are rated to 6000 psig @ 100°F with hard seats & 3000 psig @ 100°F with soft seats (Delrin for carbon steel). |
| Features | Non-rotating tip provides tight repeatable shutoff without galling or cross scoring; saves space and reduces costs |

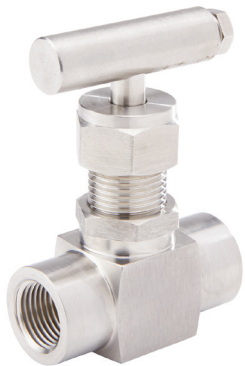

HN39

Stainless Steel Instrument Needle Valves

A compact and economical high pressure instrument block valve. All valves have integral hard seats, 316 stainless steel body and trim and Teflon/Grafoil packing.

| | |
|----------|---|
| Sizes | 1/8", 1/4", 3/8", 1/2", 3/4", 1", 6mm, 8mm, 10mm, 14mm, 18mm, 25mm |
| Ratings | Stainless steel to 6980 psig @ 100°F. 450°F limit for Teflon packed valves. 1000°F limit for Grafoil packed valves. |
| Features | Non-rotating tip provides tight repeatable shutoff without galling or cross scoring; integral body & bonnet design |

EN39

Economical Needle Valves

All valves are available with integral hard seats, 316-NACE stainless steel body and trim and Teflon or Graphite packing. Hastelloy C and Monel available upon request.

| | |
|----------|---|
| Sizes | 1/4" & 1/2" |
| Ratings | Stainless steel with TFE packing: 6000 psig @ 100°F; 4200 psig @ 400°F |
| Features | Non-rotating tip provides tight repeatable shutoff without galling or cross scoring; compact & economical |





HN41

Roddable Instrument Needle Valves

A straight-thru design with Delrin seat which provides bi-directional flow and the ability to "rod-out" the valve for cleaning. Specifically targeted for oil & gas industry.

| | |
|----------|---|
| Sizes | 1/4" & 1/2" |
| Ratings | 6000 psig @ 100°F |
| Features | Roddable design; rising plug design for better shutoff; thread in bonnet above packing; larger handle and stem diameter |

HN49

Instrument Needle Valves

A heavy duty needle valve that features an industrial strength stem and bonnet and enhanced packing arrangement, all designed to handle the tough conditions of high pressure and high temperature services.

| | |
|----------|---|
| Sizes | 1/8", 1/4", 3/8", 1/2", 3/4", 1", 6mm, 8mm, 10mm, 14mm, 18mm, 25mm |
| Ratings | 6980 psig @ 100°F; 3525 psig @ 1000°F (stainless steel); 6580 psig @ 100°F; 4300 psig @ 650°F (carbon steel) 450°F limit for Teflon |
| Features | Wide selection of body/bonnet and packing materials; non-rotating stem; backseated bonnets with packing below the stem threads |

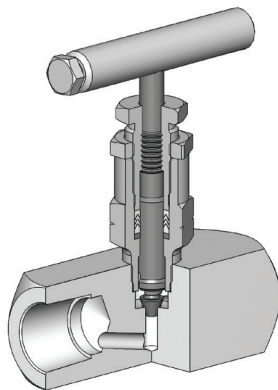

HN490

10,000# Instrument Needle Valves

The 10,000# bonnet assembly was added to meet the very high pressure requirements in oil & gas production, specifically on offshore drilling platforms.

| | |
|--------------|--|
| Sizes | 1/4", 3/8", 1/2", 3/4", 1" |
| Ratings | 10,000 psig @ 100°F or 6900 psig @ 450°F. Bonnet is only available with Teflon packing |
| Applications | Shut off for most fluids including steam; compressors; hydraulic and pneumatic applications; calibration & testing |

HN49U

Union Bonnet Needle Valves

Severe service union-bonnet needle valve that features a one-piece forged body and grafoil packing designed to handle the extreme conditions of high pressure and temperature services.

| | |
|----------|--|
| Sizes | 6mm & 10mm orifice sizes |
| Ratings | 10,000 psig @ 100°F; 3500 psig @ 1200°F |
| Features | Backseated bonnets with packing below the stem threads; panel mounting standard; non-rotating ball tip stem provides for repeatable, leak-tight shutoff |



PRIMARY GAUGE VALVES

HG35

Gauge Valves

Meets the application requirement for a block & bleed valve without the need for a close nipple when connecting to a female port on a gauge pressure transmitter.

| | |
|----------|---|
| Sizes | 1/4", 3/8", 1/2", 3/4", 1" |
| Ratings | 6980 psig @ 100°F; 3525 psig @ 1000°F (Stainless Steel with graphite packing); 450°F limit for Teflon |
| Features | Threads in the bonnet are above the stem packing to eliminate possible thread contamination; non-rotating tip provides tight repeatable shutoff; save money by reducing the number of components; reduces number of leak points |



EG35

Economical Gauge Valves

Meets the application requirement for a block & bleed valve without the need for a close nipple when connecting to a female port on a gauge pressure transmitter.



| | |
|----------|--|
| Sizes | 1/2" & 3/4" |
| Ratings | Stainless steel with TFE packing: 6000 psi @ 100°F; 4200 psig @ 400°F |
| Features | Valves available with integral hard seats, 316-NACE stainless steel body and trim and Teflon or Graphite packing |

HG46

Gauge Valves

A quick, inexpensive and compact means of installing gauges and static pressure instrumentation. Can be supplied with a bleed valve or needle valve threaded into one of the outlets to allow for combined block & bleed functions in a single, compact unit.

| | |
|----------|---|
| Sizes | 1/4", 3/8", 1/2", 3/4", 1" |
| Ratings | 6980 psig @ 100°F; 3525 psig @ 1000°F (Stainless Steel with graphite packing); 450°F limit for Teflon |
| Features | Compact design; non-rotating tip; OS&Y bonnet for added safety; packing below the threads prevents lubricant wash out and corrosion |

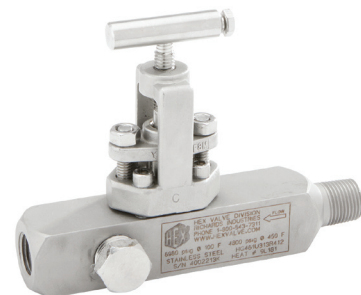

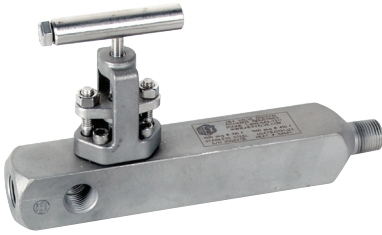

HG47

Gauge Valves

A roddable, hard seated orifice valve. Ideal for use on high temperature, viscous service. Provides full port, unrestricted flow.

| | |
|----------|--|
| Sizes | 1/4", 3/8", 1/2", 3/4", 1" |
| Ratings | 6980 psig @ 100°F; 3525 psig @ 1000°F (Stainless Steel with graphite packing); 450°F limit for Teflon |
| Features | Cost savings by reducing number of components and leak points; compact design, Non-rotating tip; packing below the threads prevents lubricant washout and corrosion. |

HG48

Gauge Valves

Provides three outlet connections to facilitate the mounting of gauges and other static pressure instruments in a variety of positions.

| | |
|----------|---|
| Sizes | 1/4", 3/8", 1/2", 3/4", 1" |
| Ratings | 6980 psig @ 100°F; 3525 psig @ 1000°F (Stainless Steel with graphite packing); 450°F limit for Teflon |
| Features | Cost savings by reducing number of components and leak point; compact design; non-rotating tip; packing below threads prevents lubricant wash out and corrosion |



EG48

Economical Gauge Valves

Provides three outlet connections to facilitate the mounting of gauges and other gauge pressure instruments in a variety of positions. Integral hard seat matches body material.

| | |
|----------|---|
| Sizes | 1/2" & 3/4" |
| Ratings | SS with TFE packing & hard seat: 6000 psig @ 100°F; 4200 psig @ 400°F |
| Features | All valves are available with integral hard seats; 316-NACE stainless steel body & trim; Teflon or Graphite packing |

HG65

Orifice Block Valves

Designed for compact side-by-side mounting on standard orifice flanges, condensate chambers, mercury traps and seal traps. Two outlet ports are provided for impulse line connections or for pressure mounting.

| | |
|----------|--|
| Sizes | 1/4", 3/8", 1/2", 3/4", 1" |
| Ratings | 6980 psig @ 100°F; 3525 psig @ 1000°F (Stainless Steel with graphite packing); 450°F limit for Teflon |
| Features | Ideal for light hydrocarbons or utility service; non-rotating tip stem; VOC emission compliance; reduce cost & installation time |





EG65

Economical Orifice Block Valves

Designed for compact side-by-side mounting on standard orifice flanges, condensate chambers, mercury traps and seal traps. Two outlet ports are provided for impulse line connections or for pressure mounting.

| | |
|-----------|---|
| Sizes | 1/2" & 3/4" |
| Ratings | 6000 psig @ 100°F; 3030 psig @ 1000°F (Stainless Steel with graphite packing); 400°F limit for Teflon |
| Features: | Ideal for light hydrocarbons or utility service; reduce cost & installation time |

HG12

Orifice Block Valves

The valve features a built-in vent or bleed screw on the outlet side of the valve. In process line mounted instrument or signal line tubing, venting or line-filling capabilities can be added.

| | |
|-----------|--|
| Sizes | 1/4", 3/8", 1/2", 3/4", 1" |
| Ratings | 6980 psig @ 100°F; 3525 psig @ 1000°F (Stainless Steel with graphite packing); 450°F limit for Teflon |
| Features: | Compact, side-by-side mounting; reduce potential leakage; non-rotating tip stem; reduce cost & installation time |



H025

Orifice Block Valves

Features an OS&Y bolted bonnet and two outlet connections. The H025 is more compact and has a shorter profile than the HG65 model to reduce vibration.

| | |
|----------|--|
| Sizes | 1/4", 3/8", 1/2", 3/4", 1" |
| Ratings | 6980 psig @ 100°F; 3525 psig @ 1000°F (Stainless Steel with graphite packing); 450°F limit for Teflon |
| Features | Compact, side-by-side mounting; reduce potential leakage; non-rotating tip stem; reduce cost & installation time |

BLOCK & BLEED VALVES

HB50/51

Block & Bleed Valves

A fully packed and backseated block valve along with a bleed valve with directional discharge tube and stem stop. The HB50 can provide secondary block & bleed functions on multiple instrument installations. The HB51 utilizes a bleed screw in lieu of a bleed valve.

| | |
|----------|--|
| Sizes | 1/4", 3/8", 1/2", 3/4", 1" |
| Ratings | 6980 psig @ 100°F; 3525 psig @ 1000°F (Stainless Steel with graphite packing); 450°F limit for Teflon |
| Features | Cost savings; compact design features 2 valves in 1 to utilize less space; non-rotating tip; packing below threads |

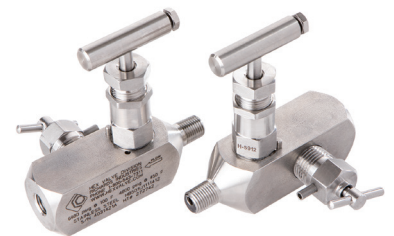

HB50 Series shown



EB50

Economical Block & Bleed Valves

A fully packed and backseated block valve along with a bleed/plug. With a gauge or transmitter threaded in its outlet, it will allow pressure to be blocked and bled for convenient instrument removal. It can also provide secondary block & bleed functions.

| | |
|----------|--|
| Sizes | 1/2" |
| Ratings | 6000 psig @ 100°F; 4200 psig @ 400°F (Stainless Steel with Teflon packing) |
| Features | Cost savings; compact design features 2 valves in 1 to utilize less space |

HB52

Bleed Tee Valves

Ideal for modernizing outdated, non-bleed gauge installations. During instrument maintenance, simply thread it into the outlet of an existing block valve. An instrument is then threaded into the HB52 outlet to complete the installation.

| | |
|----------|--|
| Sizes | 1/4", 3/8", 1/2", 3/4", 1" |
| Ratings | 6980 psig @ 100°F; 3525 psig @ 1000°F (Stainless Steel) |
| Features | Cost savings by reducing number of components and leak points; compact design features 2 valves in 1 to utilize less space |

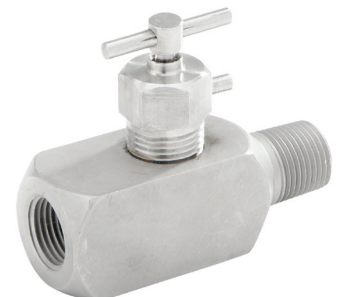

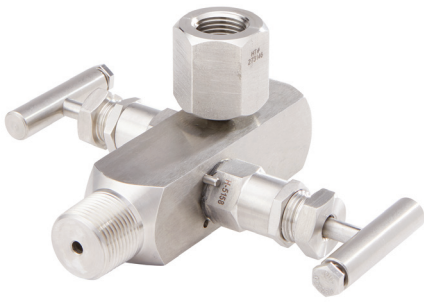

HB59

Integral Block & Bleed Valves

A fully packed backseated block and bleed valve that minimizes threaded connections. Typically used on applications where waste must be returned to the line or holding vessel.

| | |
|----------|--|
| Sizes | 1/4", 3/8", 1/2", 3/4", 1" |
| Ratings | 6980 psig @ 100°F; 3525 psig @ 1000°F (Stainless Steel with graphite packing); 450°F limit for Teflon |
| Features | Cost savings; compact design; non-rotating tip; packing below the threads prevents lubricant washout and corrosion |

HB24/25/26/27

Block & Bleed Valves

Available individually or optionally threaded into an unused outlet port on a variety of models. Used for bleeding off high pressure media.

| | |
|----------|---|
| Sizes | 1/4", 3/8", 1/2", 3/4" |
| Ratings | 6980 psig @ 100°F; 3525 psig @ 1000°F (Stainless steel) |
| Features | Reduce costs and installation time |



HG35

Block & Bleed Valves

Meets the application requirement for a block & bleed valve without the need for a close nipple when connecting to a female port on a gauge pressure transmitter.

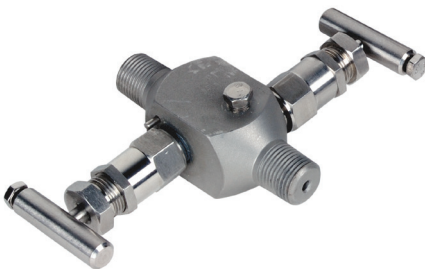

| | |
|----------|---|
| Sizes | 1/4", 3/8", 1/2", 3/4", 1" |
| Ratings | 6980 psig @ 100°F; 3525 psig @ 1000°F (Stainless Steel with graphite packing); 450°F limit for Teflon |
| Features | Threads in the bonnet are above the stem packing to eliminate possible thread contamination; non-rotating tip provides tight repeatable shutoff; save money by reducing the number of components; reduces number of leak points |

EG35

Economical Block & Bleed Valves

Meets the application requirement for a block & bleed valve without the need for a close nipple when connecting to a female port on a gauge pressure transmitter.

| | |
|----------|--|
| Sizes | 1/2" & 3/4" |
| Ratings | Stainless steel with TFE packing: 6000 psi @ 100°F; 4200 psig @ 400°F |
| Features | Valves available with integral hard seats, 316-NACE stainless steel body and trim and Teflon or Graphite packing |

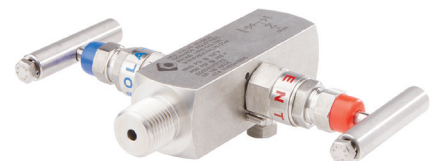

HEXBLOK VALVES

HEXBLOK

Ball Valves

Used primarily on upstream offshore/onshore oil production and initial processing installations. Typically used on liquid hydrocarbon applications to minimize the size and weight of the pipe-valve assemblies associated with gauge pressure or analytical instrumentation.

| | |
|----------|---|
| Sizes | 1/2" - 2" |
| Ratings | In accordance to ASME B16.5 for class 150 to 2500 up to 6000psi. Working temperatures up to 450°F for Teflon & Graphite packing and PEEK seals |
| Features | Compact; rigid; lighter; safer; lower cost than conventional piping methods; reduced link points; pressure point closer to pressure measurement |



HEXBLOK

Needle Valves

Used primarily on upstream offshore/onshore oil production and initial processing installations. Typically used on liquid hydrocarbon applications to minimize the size and weight of the pipe-valve assemblies associated with gauge pressure or analytical instrumentation.

| | |
|----------|--|
| Sizes | 1/2" - 2"; 10mm Bore/Orifice sizes |
| Ratings | In accordance to ASME B16.5 for class 150 to 2500 450°F for Teflon packing; 1000°F for Graphite packing |
| Features | Large standard orifice and porting; large, robust bonnet and NRT stem design means longer life, less breakage; non-rotating stem tip |

MONOFLANGE VALVES

MONOFLANGE

Monoflange Valves

Applications: pressure instrument take-off points, sampling systems, chemical injection systems, hydraulic power units, high pressure fire safe valves, drains for tanks and pipes where space is limited.

| | |
|----------|---|
| Sizes | Flange in accordance to ASME B16.5 |
| Ratings | Class 150 to 2500. Working Temperatures up to 1000°F |
| Features | Compact; rigid; lighter; safer; lower cost than conventional piping methods; reduced link points; pressure point closer to pressure measurement |



MONOWELD VALVES

MONOWELD

Monoweld Valves

Used on upstream offshore/onshore gas & oil production and initial processing installations. Typically used on single or dual gauge pressure or analyzer installations to minimize the size & weight of the pipe-valve assemblies.

| | |
|----------|--|
| Sizes | 1/4", 3/8", 1/2", 3/4", 1" |
| Ratings | In accordance to ASME B16.5 for class 150 to 2500 450°F for Teflon packing; 1000°F for Graphite packing |
| Features | Integral Weldolet® means one weld instead of two per gauge pressure or analyzer take off, reduces total installation height and weight |

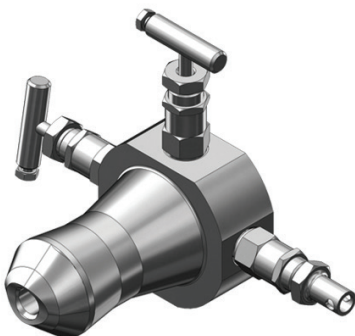

MONOBALL VALVES

MONOBALL

Monoball Valves

Designed for direct shutoff of flow like any ball valve. The difference is the compact design and light weight. It can be used in conjunction with other valves to allow for a safer shutoff creating a double block for safety.

| | |
|----------|---|
| Sizes | 1/2" - 2" |
| Ratings | ANSI B16.34 flange ratings for Class 150 - 2500# flanges 10000 psig @ 100°F with Carbon PEEK Seats or 6250 psig @ 100°F with standard PEEK Seats |
| Features | Small, thin design and lightweight; design allows you to combine with other valves in series for safe shutoff; 10mm through bore; API 607 5th Edition Fire Safe |

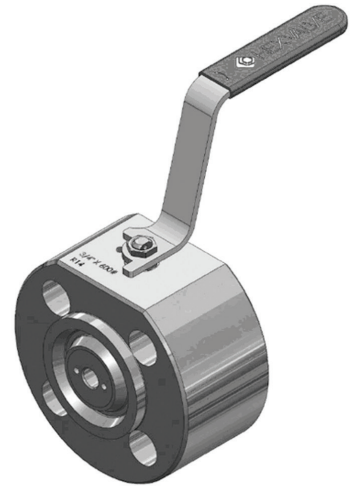

TWO VALVE MANIFOLD VALVES

HM50

Static Pressure Manifold Valves

A single flanged static pressure manifold that includes a primary block valve, a secondary shutoff valve and a bleed valve into a single valve assembly. The secondary shutoff and bleed valve allows the gauge and transmitter to be vented and/or removed.

| | |
|----------|---|
| Sizes | 1/2" x Instrument Flange |
| Ratings | 6980 psig @ 100°F; 3525 psig @ 1000°F (Stainless Steel with graphite packing); 450°F limit for Teflon |
| Features | Reduce costs and installation time; non-rotating tip stem; fully backseated bonnets |

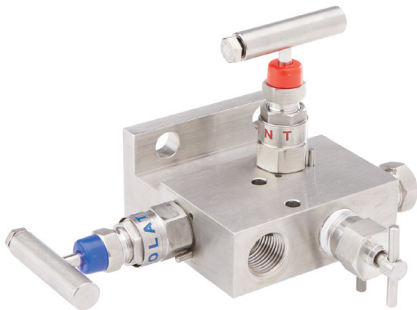
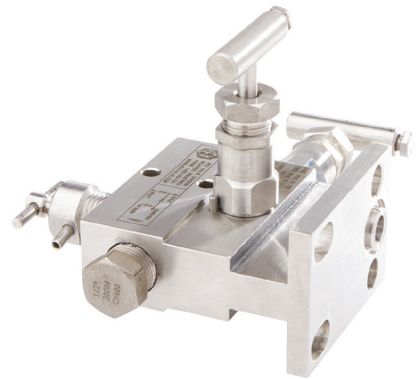

EM50

Economical Static Pressure Manifold Valves

A single flanged, static pressure manifold that incorporates a block valve and a vent valve into a single valve assembly. The side vent outlet is plugged, allowing removal during maintenance or the installation of a calibration fitting.

| | |
|----------|---|
| Sizes | 1/2" x Instrument Flange |
| Ratings | 6000 psig @ 100°F; 4200 psig @ 400°F (Stainless Steel with TFE packing) |
| Features | Compact & economical |

HM59

Static Pressure Manifold Valves

A line-mounted two valve manifold that functions as a shutoff and vent valve for static pressure instrumentation. Provides separate instrument bleed and a calibration entry port to allow for fast, accessible zeroing and calibration of gauge pressure transmitters.

| | |
|----------|--|
| Sizes | 1/4", 1/2", 3/4", 1" |
| Ratings | Stainless Steel: 6980 psig @ 100°F & 3525 psig @ 1000°F Carbon Steel: 6580 psig @ 100°F & 4300 psig @ 650°F |
| Features | Low cost; easy to install; non-rotating tip stem; fully backseated bonnets |

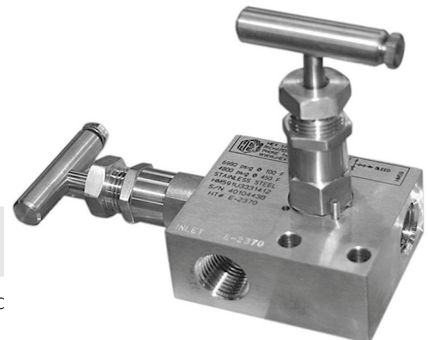



EM59

Economical Gauge Pressure Manifold Valves

A compact remote two valve manifold that functions as a shutoff and vent valve for static pressure instrumentation. It reduces the number of threaded connections, resulting in fewer potential leak points.

| | |
|----------|---|
| Sizes | 1/2" |
| Ratings | 6000 psig @ 100°F; 4200 psig @ 400°F (Stainless Steel with TFE packing) |
| Features | Easy to install; less material and labor costs |

HM58

Level Manifold Valves

Simplified, lower cost alternatives to traditional manifolds used in D/P level installations. Eliminates the need for tubing, fittings, instrument pipe stands and their associated installation costs.

| | |
|----------|--|
| Sizes | 1/2", 1", 1-1/2", 2", 3", 4" |
| Ratings | 6980 psig @ 100°F; 3525 psig @ 1000°F (Stainless Steel with graphite packing); 450°F limit for Teflon |
| Features | Can be used for vented or closed tank, bottom or side-mounted installations or for tank top mounted bubbler installations. |

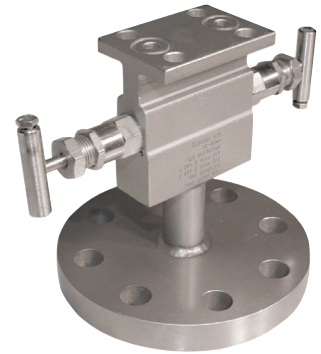

THREE VALVE MANIFOLD VALVES

HM45

In-line Manifold Valves

A general purpose instrument manifold designed for connecting differential pressure transmitters to impulse line tubing. Connectors are 1/2" NPT on industry standard 2-1/8" center-to-center dimensions).

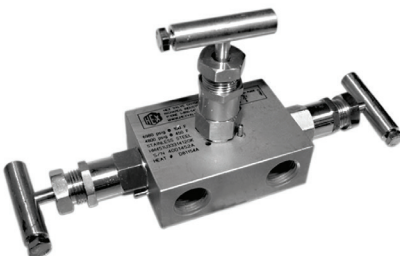

| | |
|----------|---|
| Sizes | 1/4", 3/8", 1/2", 3/4", 1" |
| Ratings | 6980 psig @ 100°F; 3525 psig @ 1000°F (Stainless Steel with graphite packing); 450°F limit for Teflon |
| Features | VOC emission compliance; non-rotating tip stem; minimum emission flange; removable bracket option |



EM45

In-line Manifold Valves

A general purpose instrument manifold designed for connecting differential pressure transmitters or flow recorders to impulse line tubing.

| | |
|----------|---|
| Sizes | 1/2" |
| Ratings | 6000 psig @ 100°F; 4200 psig @ 400°F (Stainless Steel with TFE packing) |
| Features | Available with integral hard seats; 316-NACE Stainless Steel body & trim and Teflon or Graphite Packing |

HM46

In-line Manifold Valves with Vent

The same design as the HM45 but also incorporating a vent valve allowing a technician to perform instrument bleed or blowdown procedures

| | |
|----------|---|
| Sizes | 1/4", 3/8", 1/2", 3/4", 1" |
| Ratings | 6980 psig @ 100°F; 3525 psig @ 1000°F (Stainless Steel with graphite packing); 450°F limit for Teflon |
| Features | VOC emission compliance; non-rotating tip stem; minimum emission flange; removable bracket option |

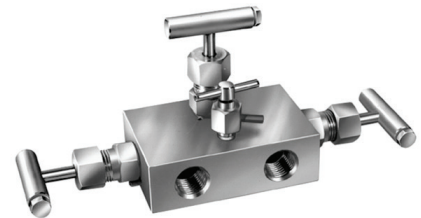

HM53

Single Flanged Manifolds

Used to perform the block, equalizing and vent requirements of differential pressure transmitter applications. The single mounting flange allows the transmitter to bolt directly to the manifold, eliminating the piping of excess tubing and nipples.

| | |
|----------|---|
| Sizes | 1/2" x Instrument Flange |
| Ratings | 6980 psig @ 100°F; 3525 psig @ 1000°F (Stainless Steel with graphite packing); 450°F limit for Teflon |
| Features | VOC emission compliance; non-rotating tip stem; minimum emission flange; removable bracket option |



EM53

Economical Single Flanged Manifolds

Used to perform the block, equalizing and vent requirements of differential pressure transmitter applications. Has a single mounting flange allowing the transmitter to bolt directly to the manifold.

| | |
|----------|---|
| Sizes | 1/2" x Instrument Flange |
| Ratings | 6000 psig @ 100°F; 4200 psig @ 400°F (Stainless Steel with TFE packing) |
| Features | Available with integral hard seats; 316-NACE stainless Steel body & trim and Teflon or Graphite Packing |

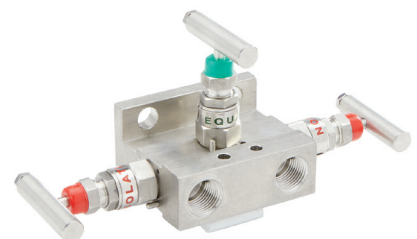

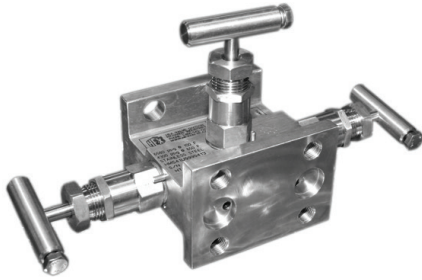

HM54

Double Flanged Manifold Valves

Used to perform the block, equalizing and vent requirements of differential pressure transmitters. The manifold can bolt directly to the instrument and can be mated directly to the orifice flange using futbol flanges and short nipples

| | |
|----------|---|
| Sizes | Instrument Flange x Instrument Flange |
| Ratings | 6980 psig @ 100°F; 3525 psig @ 1000°F (Stainless Steel with graphite packing); 450°F limit for Teflon |
| Features | VOC emission compliance; non-rotating tip stem; minimum emission flange; removable bracket option |

EM54

Economical Double Flanged Manifold Valves

Used to perform the block, equalizing and vent requirements of differential pressure transmitters. The manifold can bolt directly to the instrument and can be mated directly to the orifice flange using futbol flanges and short nipples

| | |
|----------|--|
| Sizes | Instrument Flange x Instrument Flange |
| Ratings | 6000 psig @ 100°F; 4200 psig @ 400°F (Stainless Steel with TFE packing) |
| Features | VOC emission compliance; minimum emission flange; removable bracket option |

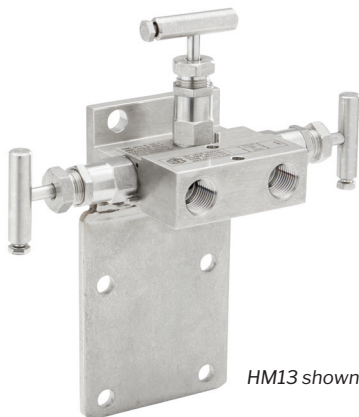
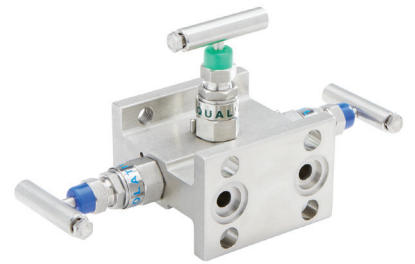

HM13 shown

HM10/13/14/16/18

Rigid Mount Manifold Valves

The rigid mount manifolds feature an integral mounting flange, eliminating the extra bolting associated with a transmitter mounting bracket.

| | |
|----------|---|
| Sizes | 1/2" x Instrument Flange |
| Ratings | 6980 psig @ 100°F; 3525 psig @ 1000°F (Stainless Steel with graphite packing); 450°F limit for Teflon |
| Features | Non-rotating tip stem; your choice of mounting options; fully packed bonnets |

FIVE VALVE MANIFOLD VALVES

HM57

Manifold Valves

Two shutoff valves, two equalizing valves and a vent/calibration valve in a single, compact assembly. The double equalizing arrangement insures against measurement error that can occur from equalizer leakage between high and low pressure connections.

| | |
|----------|--|
| Sizes | 1/2", Flanged |
| Ratings | 6980 psig @ 100°F; 3525 psig @ 1000°F (Stainless Steel with graphite packing); 450°F limit for Teflon |
| Features | Reduce costs & installation time; integral vent/calibration valve; fewer leak points; your choice of mounting styles |

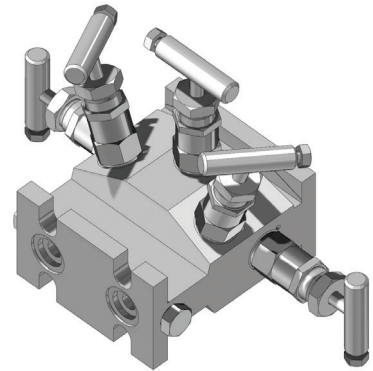

EM57

Economical Manifold Valves

Two shutoff valves, two equalizing valves and a vent/calibration valve in a single, compact assembly. The double equalizing arrangement insures against measurement error that can occur from equalizer leakage between high and low pressure connections.

| | |
|----------|---|
| Sizes | 1/2", Flanged |
| Ratings | 6000 psig @ 100°F; 4200 psig @ 400°F (Stainless Steel with TFE packing) |
| Features | Precise measurement; ideal for custody transfer or other critical flows |

HM37

Manifold Valves

Two isolation valves, two equalizing valves and a vent/calibration valve in a single, compact assembly. When expensive liquid or gas changes ownership, precise measurement is critical.

| | |
|----------|---|
| Sizes | Flanged |
| Ratings | 3000 psig @ 100°F; 1500 psig @ 200°F |
| Features | User friendly design; longer body; mounting taps for universal bracket installation; o-ring bonnets; 2 configurations |

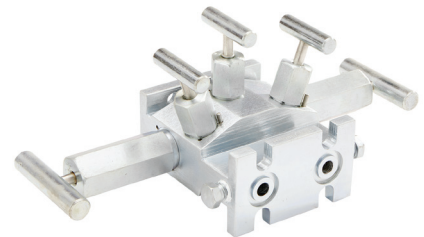

NATURAL GAS VALVES

HE30

Equalizing Valves

A compact and cost effective alternative to the more costly five-valve manifold. Delrin or Teflon soft seat valves insure redundant equalizer isolation, eliminating the possibility of costly leaks there or through the vent/calibrate valve

| | |
|----------|--|
| Sizes | 1/4" |
| Ratings | 1500 psig @ 100°F; 500 psig @ 200° F |
| Features | Delrin seats insure tight shutoff; offset vent valve for ergonomic handle operation, non-rotating tip stem |

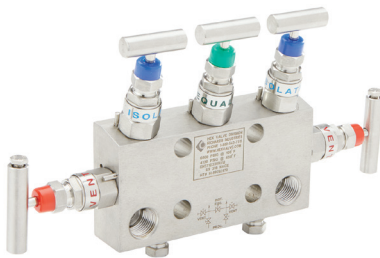
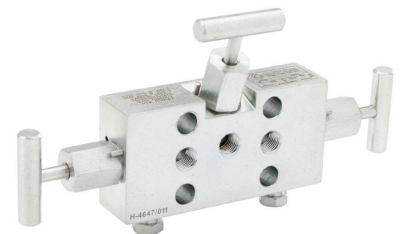

EH37

Economical Manifold Valves

Designed for direct mounting to the transmitter with a threaded inlet and instrument flanged outlet. The unique, compact barstock design makes this a good choice when a direct mount manifold with vent and calibration access is crucial

| | |
|----------|---|
| Sizes | 1/2" |
| Ratings | 6000 psig @ 100°F; 4200 psig @ 400°F (Stainless Steel with TFE packing) |
| Features | Designed for direct mounting to the transmitter with a threaded inlet and instrument flanged outlet. The unique, compact barstock design makes this an economical choice when direct mounted manifold with vent and calibration access is crucial |

HM37

Manifold Valves

Two isolation valves, two equalizing valves and a vent/calibration valve in a single, compact assembly. When expensive liquid or gas changes ownership, precise measurement is critical.

| | |
|----------|---|
| Sizes | Flanged |
| Ratings | 3000 psig @ 100°F; 1500 psig @ 200°F |
| Features | User friendly design; longer body; mounting taps for universal bracket installation; o-ring bonnets; 2 configurations |

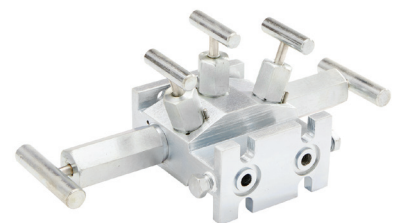

POWER VALVES

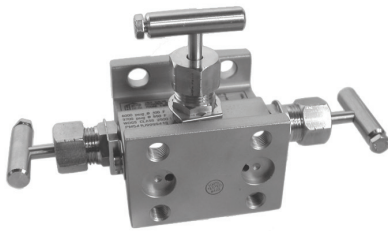

PM54 Series shown

PM SERIES

Three & Five Valve Power Manifold Valves

A complete line of three and five valve instrument manifolds for the power industry. For in-line, single flanged for mounting, double flanged for direct mounting and direct mounted compact wafer.

| | |
|----------|---|
| Sizes | 1/2", 3/4", Flanged |
| Ratings | 6000 psig @ 100°F; 3030 psig @ 1000°F (Stainless Steel with Graphite Packing) |
| Features | Conforms to the Power Standards ANSI B31.1 and B31.3 specifications |

PM SERIES

Two Valve Power Manifold Valves

Available as a primary block valve, bleed valve and secondary shutoff valve into one small unit, or a line-mounted manifold that functions as a shutoff and bleed valve for static pressure instrumentation.

| | |
|----------|---|
| Sizes | 1/2", 3/4", Flanged |
| Ratings | 6000 psig @ 100°F; 3030 psig @ 1000°F (Stainless Steel with Graphite Packing) |
| Features | Conforms to the Power Standards ANSI B31.1 and B31.3 specifications |

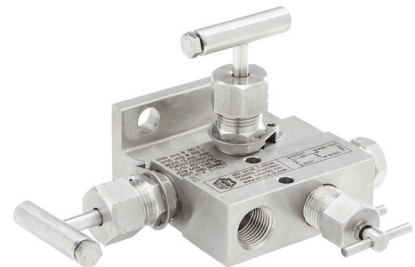

PM50 Series shown

PM75

Power Manifold Valves

Designed for remote mounting of differential pressure transmitters. It includes two isolation valves, one test valve and two test/purge valves. The manifold can be mounted via pipe stand or instrument rack.

| | |
|----------|---|
| Sizes | 1/2", 3/4", Flanged |
| Ratings | 6000 psig @ 100°F; 3030 psig @ 1000°F (Stainless Steel with Graphite Packing) |
| Features | Conforms to the Power Standards ANSI B31.1 and B31.3 specifications |



PM76

Five Valve Power Manifold Valves



Designed for direct mounting to transmitter by unique wafer design. The compact design eliminates the requirement for additional tubing or piping from manifold to transmitter.

| | |
|----------|---|
| Sizes | 1/2", 3/4", Flanged |
| Ratings | 6000 psig @ 100°F; 3030 psig @ 1000°F (Stainless Steel with Graphite Packing) |
| Features | Conforms to the Power Standards ANSI B31.1 and B31.3 specifications |

PM10/13/14/16/18

Rigid Mount Power Manifold Valves

Can mount directly to the pipe stand securing the impulse lines so the transmitter can be installed or removed independently of the piping.

| | |
|----------|---|
| Sizes | 1/2", 3/4", Flanged |
| Ratings | 6000 psig @ 100°F; 3030 psig @ 1000°F (Stainless Steel with Graphite Packing) |
| Features | Conforms to the Power Standards ANSI B31.1 and B31.3 specifications |

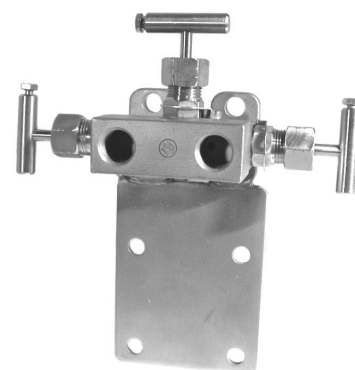

PG46

Gauge Power Valves

Provides three outlet connections to facilitate the mounting of gauges and other static pressure instrumentation in a variety of positions. The design results in a compact installation with minimal leak points.

| | |
|----------|---|
| Sizes | 1/4", 1/2", 3/4", 1" |
| Ratings | 6000 psig @ 100°F; 3030 psig @ 1000°F (Stainless Steel with Graphite Packing) |
| Features | Conforms to the Power Standards ANSI B31.1 and B31.3 specifications |

PN49

Needle Power Valves

A fully packed needle valve for high pressure and high temperature applications. Produced in a wide variety of inlet and outlet sizes.

| | |
|----------|---|
| Sizes | 1/4", 1/2", 3/4", 1" |
| Ratings | 6000 psig @ 100°F; 3030 psig @ 1000°F (Stainless Steel with Graphite Packing) |
| Features | Conforms to the Power Standards ANSI B31.1 and B31.3 specifications |

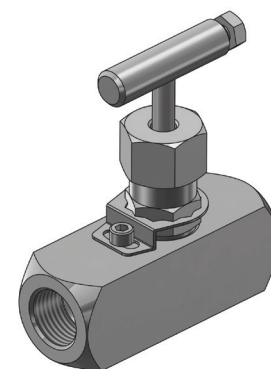

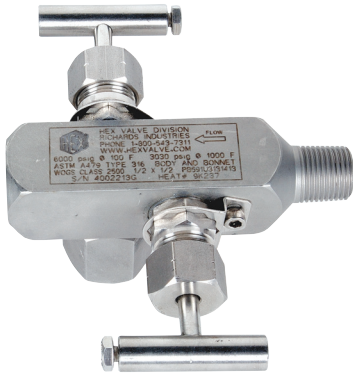

PB59

Block & Bleed Power Valves

For critical services, the PB59 block and bleed valve features a fully packed and backseated block valve along with a fully packed integral bleed valve.

| | |
|----------|---|
| Sizes | 1/4", 1/2", 3/4", 1" |
| Ratings | 6000 psig @ 100°F; 3030 psig @ 1000°F (Stainless Steel with Graphite Packing) |
| Features | Conforms to the Power Standards ANSI B31.1 and B31.3 specifications |

SPECIAL VALVES

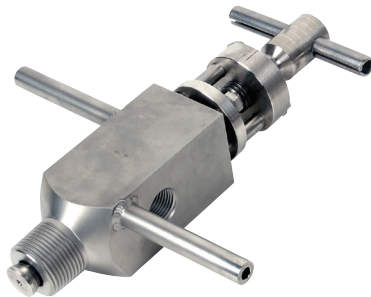

HS31

Sample/Drain Valves

A sample/drain valve used to extract a fresh sample while providing tight shutoff and high pressure and temperature capabilities.

| | |
|----------|---|
| Sizes | 3/4", 1", 1-1/2" |
| Ratings | 3100 psig @ 100°F; 2150 psig @ 1000°F (Stainless Steel with Graphite Packing) |
| Features | Wide material selection suits a variety of applications & services; reciprocating stem; dual seating option |

HA

Air & Gas Distribution Manifolds

A soft seated multi-valve manifold that allows you to connect one air/gas source to the inlet for distribution of up to twelve separate work stations. Used in place of conventional methods for the distribution of plain air and purge gases.

| | |
|----------|--|
| Sizes | 1/4", 1/2", 3/4", 1" |
| Ratings | 1500 psig @ 100°F; 500 psig @ 200°F |
| Features | Reduce costs and installation time; reduces potential leakage; integral mounting plates; fully backseated bonnets; anti-tamper handles |



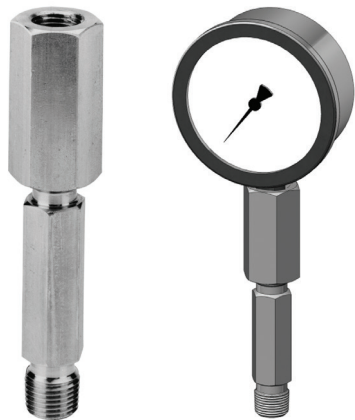

HGSY/HGVS

Gauge Syphons

Act as thermal and liquid seal barriers between hot process vapors (such as steam and heat transfer fluids) and the gauge pressure instrument. It provides maximum instrumentation protection in half the space.

| | |
|----------|---|
| Sizes | 1/4", 1/2", 3/4", 1" |
| Ratings | 6000 psig @ 100°F; 3030 psig @ 1000°F (Stainless Steel with graphite packing, if applicable) |
| Features | Minimizes space/radius requirements; minimizes deflection stress; thermal protection; leak point minimization |



3170 Wasson Rd. Cincinnati, OH 45209

P: 513.533.5600 • F: 513.871.0105

www.hexvalve.com

hex@richardsind.com