



HEX VALVE

3170 Wasson Road • Cincinnati, OH 45209 USA
 Phone 513-533-5600 • Fax 513-871-0105
 hex@richardsind.com • www.hexvalve.com

I & M SpringTite Connector for Orifice Flange Unions

Installation & Maintenance Instructions for SpringTite Stabilized Connector

Warning: Hex Valves must only be used, installed, and repaired in accordance with these Installation & Maintenance Instructions. Observe all applicable public and company codes and regulations. In the event of leakage or other malfunction, call a qualified service person; continued operation may cause system failure or a general hazard.

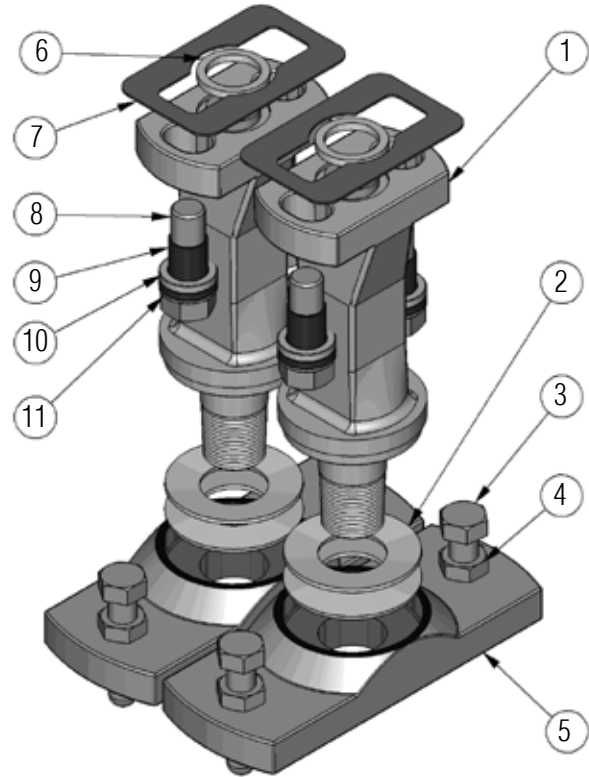
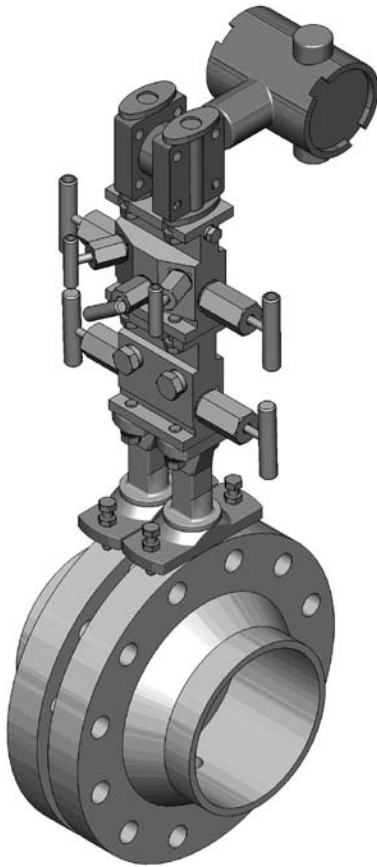

Installation

Stabilized Connectors

Connectors are shipped loosely assembled as shown in illustration above. Tools needed for assembly include 9/16" open end wrench for base jack screws (4) and nuts (5) and 5/8" open end wrench for manifold mounting kit bolts (9). A 1" open end wrench can be used to install the connectors. Connectors may be mounted vertically as shown or horizontally.

Caution: Make certain that there is no pressure in the orifice fitting before loosening any fittings or joints.

1. Wrap each 1/2" NPT connection with minimum of three wraps of Teflon tape. Mount each connector (1) to orifice fitting by sliding through the two Belleville washers (2), base bracket (5) and threading the 1/2" NPT end connection into the orifice fitting.
2. Tighten connectors (1) to seal and align flange ends to correspond to manifold valve base, using 1" wrench. Surface of

each flange should be adjusted to the same height.
CAUTION – Always tighten NPT joint to adjust this height. Loosening any NPT joint could result in a joint leak.

3. Compress the stack of two Belleville washers (1) inside the base bracket (5) by extending the four jack screws (3) with the 9/16" wrench until the stop on the connectors (1) contacts the base bracket (5). Check both connectors to insure this gap is closed; do not tighten further. Lock jack screws (3) in place with lock nuts (4).
4. Connect manifold to connector flanges (1) using two Teflon gaskets (6) and two optional dielectric shims (6). Using the four dielectric bolts (8), bushings (9) and washers (10 & 11) stacked as shown or use standard bolts with lockwashers.
5. Connect manifold by torquing bolts (8) to 50-55 ft-lbs using a 5/8" wrench.

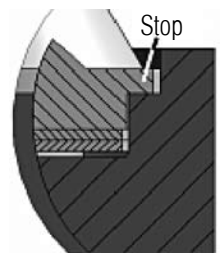

Maintenance

Stabilized Connectors

No regular maintenance is necessary. Gaskets (6) should be replaced if manifold is removed.