



# HEX VALVE

3170 Wasson Road • Cincinnati, OH 45209 USA  
Phone 513-533-5600 • Fax 513-871-0105  
hex@richardsind.com • www.hexvalve.com

## I & M Hexblok Ball Valves

### Installation & Maintenance Instructions for Hexblok and MonoBall Valves

**Warning:** Hex Valves must only be used, installed, and repaired in accordance with these Installation & Maintenance Instructions. Observe all applicable public and company safety codes and regulations. In the event of leakage or other malfunction, call a qualified service person; continued operation may cause system failure or a general hazard.

### **Please read these instructions carefully!**

Your Hex Valve product will provide you with long, trouble-free service if it is correctly installed and maintained. Spending a few minutes now reading these instructions can save hours of trouble and downtime later. When making repairs, use only genuine Hex Valve parts, available for immediate shipment from the factory.

### **Scope**

This manual is intended as a guide to assist customers in the storage, installation, and maintenance of Hexblok ball valves. Subsequent additions or special instructions will be provided for special valves, critical service or customer requirements.

### **Applicability**



### **Caution**

**To help prevent injury to personnel or damage to equipment, please read this section completely before performing any operations.**

1. Valve pressure ratings are based on many variables, including valve series and size, as well as body, seat and bolt material. Verify that application does not exceed the pressure or temperature rating on the name plate.
2. Always depressurize the line where the valve is installed, before removal or disassembly. Cycle valve in depressurized line before removing valve. Make sure that all pressure is released from inside the valve before removal or disassembly.
3. Wear protective equipment and take appropriate precautions to safeguard against injury caused by the discharge of trapped fluids.

4. Use only Hex Valve recommended spare parts for maintenance.
5. To ensure safety and maintain warranty, never modify valve in any way without prior approval from Hex Valve.

### **Storage**

All valves are adequately packed in a strong cardboard case in such a way as to avoid any possible damage during transport and storage.

*Caution: if ball valves are not destined for immediate use, the following precautions should be taken:*

1. If possible, leave the ball valves in their packing cases during the period of storage.
2. Ball valves must remain in open position during this time.
3. In order to prevent damage, protective plastic covers on valve ends should not be removed until immediately prior to installation.
4. It is advisable to store the valves in waterproof conditions. Ball valves should be protected to safeguard against humidity, moisture, dust, dirt, sand, mud, salt spray and seawater.
5. All valves complete with actuators are to be stored in dry conditions.
6. Valves to be stored for a long period of time should be checked by the quality control personnel every six months.

#### *Maintenance During Storage Period*

- Internal surface should be inspected to check for dust or other foreign objects.
- Rust or dust must be removed by cleaning with proper solvent.
- After cleaning, ball valves must be lubricated with an adequate lubricant.
- Ball valves should be operated for at least two complete cycles before installing to storage.

### **Installation**

The ball valves may be installed in any position using standard pipe fitting practices.

*Caution: before installation of the valve:*

1. Pipe must be free of tension both during and after installation
2. Pipe must be flushed to clean dirt, welding residues, etc. which would damage ball or seats
3. The valve should be kept in Open Position during installation and protective plastic covers must be removed only at the moment of installation.

4. Before shipment, the ball is lubricated with a pure Vaseline oil. This can be easily removed with an application compatible solvent if required.
5. If the valve was specified to be tested per ASME 16.34, there may be some trapped water between the ball and the body cavity. This can be removed by partially opening the valve, thereby exposing the cavity to the through port of the ball.
6. Special care should always be taken when installing automated ball valves that the ball is in the proper position.

#### *Installation of Threaded Ends*

1. Unless otherwise specified, pipe threads are American National Standard Taper Pipe Threads (NPT) per ANSI B1.20.1, and require that a pipe sealant be used.
2. Using an anti-seize thread sealant to seal and prevent galling.
  - a. Hex Valve recommends PTFE-based liquid sealant or Grafoil tape as thread sealants.
  - b. Notes:
    1. Use all pipe sealant products in accordance with the manufacturer's instructions and good piping practices.
    2. Correct lubricant of stainless steel pipe threads is especially important to prevent galling.
3. To prevent distortion or damage to the valve, do not apply torque through the valve. When tightening valve, use wrench on the end nearest the pipe being tightened.
4. Always leak test the system before using.

#### *Installation of Flanged Ends*

1. Verify valve is in the full open position
2. Use the appropriate size bolt and heavy hex nut (not included) as recommended for flange size and class
3. Flange connection requires gasket (not included)
4. Following gasket manufacturer's recommended practice for tightening flanged bolts.

### **Manual Operation**

1. Open and close the valve by turning the handle one-quarter turn (90°)
2. Valve is in open position when handle is in line with pipe
3. Valve is in closed position when handle is perpendicular to the pipe

### **Maintenance**

Before starting maintenance, please read information contained in the Caution Section of this manual.

1. Open and close the ball valve at least once to release the pressure completely from the valve body

2. Ball valves, if correctly used, normally do not need any internal lubrication and maintenance. However, when necessary, ball or seats can be replaced by qualified personnel following the instructions of this manual.
3. For further information, please refer to SPARE PARTS LIST.

### **Valve Disassembly**

*Refer cross section for part identification*

1. Valve must be in the open position
2. Remove valve from the line
3. Remove retainer (10) for inlet using a spanner wrench from the body (1)
4. If double block, remove retainer (11) from outlet by first rotating eccentric lock (27) by loosening lock bolt (28). Remove retainer (11) using 1-1/4" open end wrench.
5. Remove the outer seat (3).
6. Turn the stem to close the valve and remove the ball (2) and seat (3)
7. Remove the handle nut (8), Belleville washers (9), gland (6), thrust washer (7) and packing (5)
8. Push the stem (4) into the body (1) and remove. (For mono-ball valves, remove 1/2" pipe plug from bottom of the valve. Slide the stem out through the bottom bore.)
9. Remove o-ring (30) and thrust washer (7) from stem
10. Remove screwed bonnet bleed for inspection if applicable.

With the valve completely disassembled, clean and examine all components.

1. The surface of the ball should be free from any defect. If any are found, the ball should be replaced. Using a defective ball will be extremely detrimental to valve performance
2. Seats. Replacement of seats is recommended
3. Stem seals and body seals. Should be discarded and replaced
4. Remaining components of the valve. After cleaning, carefully examine for wear, corrosion and mechanical damage. Replace all defective parts.
5. Clean inside the body and stem housings. Light grease, compatible with line fluid, can be used on ball, seals and stem surface.

| <b>Spare Parts List</b> |                     |               |
|-------------------------|---------------------|---------------|
| Item#                   | Quantity (per ball) | Part Name     |
| 2                       | 1                   | Ball          |
| 3                       | 2                   | Seat          |
| 5                       | 1                   | Packing       |
| 7                       | 2                   | Thrust Washer |
| 13                      | 1                   | Retainer Seal |
| 30                      | 1                   | O-Ring        |

## **Re-Assembly**

---

1. Place metal thrust washer (7) and o-ring (30) over stem (4). Grease o-ring with Parker O-Lube.
2. Push wire through the top of the stem hole, and out through the inlet of the body. Twist wire through the hole in the top of the stem. **(Skip this step for monoball valves).**
3. Pull stem (4) into the body and up through the stem port until thrust washer (7) is firmly against internal stop. Remove wire. (For monoball valves, slide the stem up through the bottom bore until the thrust washer is firmly against the internal stop. Replace pipe plug when assembly is complete.)
4. Place packing (5), thrust washer (7), gland bushing (6), two Bellville washers (9), locknut (8) over stem and secure by threading locknut (8) onto the stem and tightening until the packing compresses and you feel some reasonable resistance on the stem, but loose enough that stem can still turn.
5. Place downstream seat (3) into body (1) bore of flanged inlet by angling seat under stem and pushing it flat against the bottom of the bore.
6. Place ball (2) into body bore insuring stem (4) fits loosely into ball groove. No binding of the ball on the stem is permitted. Ball must fall loosely onto the stem for the design to be safe in a fire.
7. Place upstream seat (2) into body bore parallel with downstream seat.
8. Place soft seat gasket (13) and metal gasket (14) over retainer (10) and secure ball and seats by threading into body bore.
9. Tighten retainer with spanner wrench.

10. Repeat steps 1 - 9 if valve has downstream ball, using outlet retainer (11), tighten using 1-1/4" wrench
11. Secure outlet retainer with bolt (28) and eccentric lock (27)
12. Attach handle(s) to stem(s) securing with locknut (8).
13. Secure handle stop(s) using bolt (26).
14. If valve includes screwed bonnet bleed, apply Loctite Silver Grade lubricant and thread bonnet (20) into body (1) and torque to 55 ft-lbs for carb on steel and 90 ft-lbs for stainless steel. Attach handle if not pre-assembled.

## **Testing**

---

1. After completing the reassembly, check that valve operates smoothly by opening and closing valve several times.
2. If entire valve was removed from line and if facilities area is available, test the ball valve to appropriate specifications.

## **Troubleshooting**

---

1. Stem Leakage - leakage in the stem packing area may be eliminated by increasing the torque on the stem nut (8) in one-quarter turn increments. If leakage persists, replace stem packing (5) and stem o-ring (30).
2. Body Seal Leakage - check torque on ball retainers (10 and 11). Retainer should be firmly seated against the metal gasket (14).
3. In Line or Seat Leakage - check to be sure valve is in fully closed position. If leakage persists, the valve must be disassembled and damaged parts replaced.

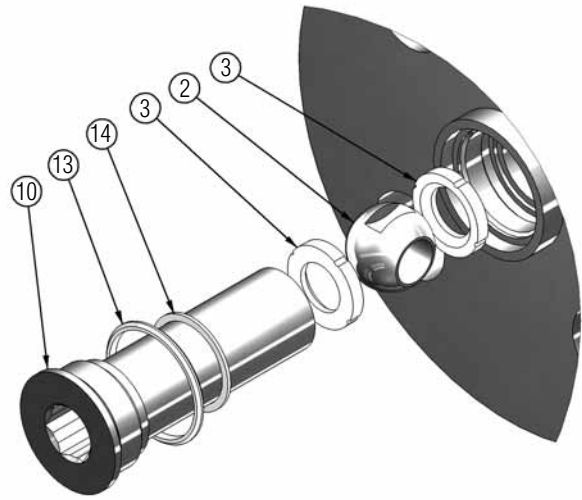
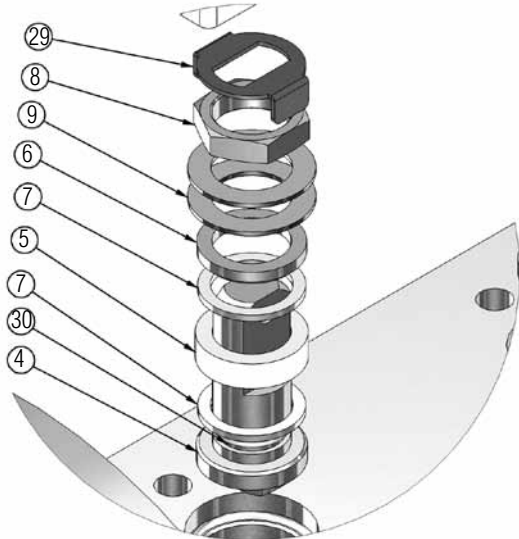
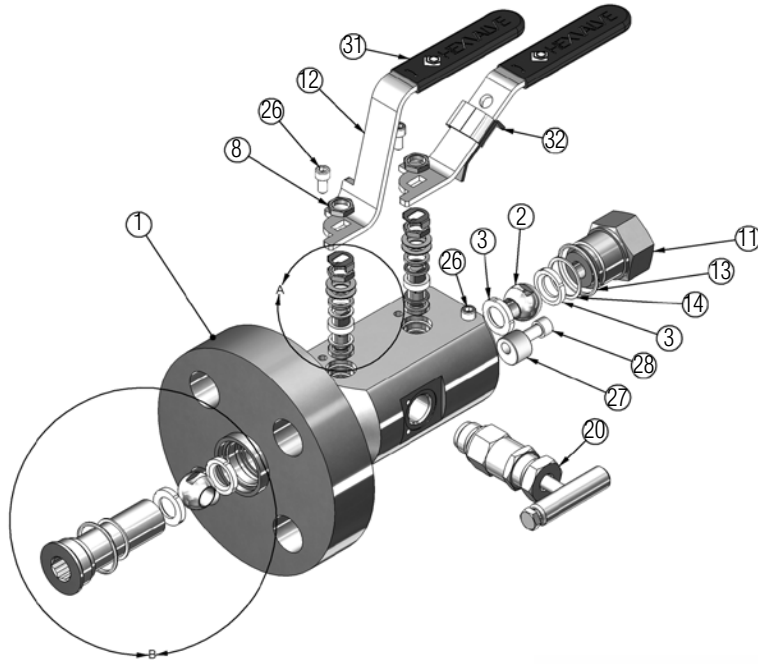

| Item # | Quantity (per ball) | Part Name        | Item # | Quantity (per ball) | Part Name       |
|--------|---------------------|------------------|--------|---------------------|-----------------|
| 1      | 1                   | Body             | 12     | 1                   | Handle          |
| 2      | 1                   | Ball             | 13     | 1                   | Retainer Gasket |
| 3      | 2                   | Seat             | 14     | 1                   | Metal Gasket    |
| 4      | 1                   | Stem             | 20     | 1                   | Screwed Bonnet  |
| 5      | 1                   | Packing          | 26     | 1                   | Handle Stop     |
| 6      | 1                   | Gland            | 27     | 1                   | Eccentric Lock  |
| 7      | 2                   | Thrust Washer    | 28     | 1                   | Lock Bolt       |
| 8      | 2                   | Nut              | 29     | 1                   | Nut Retainer    |
| 9      | 2                   | Bellville Washer | 30     | 1                   | Stem O-Ring     |
| 10     | 1                   | Retainer Inlet   | 31     | 1                   | Handle Cover    |
| 11     | 1                   | Retainer Outlet  | 32     | 1                   | Handle Lock     |