

Primary/Gauge/Block & Bleed Instrument Valves



In 1983, Richards Industries added the Hex Valve Division, a line of instrument manifolds, orifice block valves, gauge valves, needle valves and block & bleed valves to its line of industrial products. Hex Valve is known for supplying high quality products, with quick deliveries to the petrochemical, chemical, petroleum, pulp & paper, food processing and primary metal industries. Among the specialties of this product line is the readily available selection of exotic alloys such as Hastelloy, Monel, Alloy 20, Titanium and Zirconium, as well as the availability of products to meet the requirements of ANSI B31.1, ANSI B31.3 and NACE MR-01-75.

Contact your local representative for our Hex Installation Instructions. These Instructions provide additional information and ideas on proper use and installation of Hex Valve products.

Table of Contents

PRIMARY/ORIFICE BLOCK VALVES

HG65	-----	2
HG12	-----	2
HO25	-----	2

GAUGE/BLOCK VALVES

HG46	-----	6
HG48	-----	6
HG47	-----	6
HG35	-----	10

BLOCK & BLEED VALVES

HB52	-----	12
HB50	-----	12
HB59	-----	12
HB25/24/26/27	-----	13

GAUGE SYPHONS

HGVS	-----	18
HGSY	-----	18

SAMPLE/DRAIN VALVES

HS31	-----	21
------	-------	----

HIGH TEMPERATURE VALVES

HT01	-----	24
HT03	-----	24

OPTIONS AND ACCESSORIES

Bellows Stem Seal	-----	26
-------------------	-------	----

TECHNICAL DATA

Pressure/Temperature Ratings	-----	28
Stem/Seat Configurations	-----	30
NACE Specifications	-----	32
VOC Emission Compliance	-----	33

Bonnet Assembly Design

Hex Valve is the leader in a gauge, block and bleed instrument industry with its unique bonnet assembly design. Compared with competitive manufacturers' designs, Hex offers a time-tested, metal-to-metal body/bonnet seal with the largest stem diameter in the industry. Hex offers a proven Chevron design multipoint packing and Graphite/Grafoil/Graphite wiper ring arrangement for higher temperatures.

Benefit	Feature	Advantage
Our stems will provide longer service life, particularly under adverse conditions	Minimum diameter of the Hex stem is larger than any competitor	Our stem is less likely to break under normal and excessive rotational torque
Hex valves are less likely to leak (emissions) than the competitors' standard design, minimizing emission auditing costs	Packing: five rings of Teflon Chevron for low to medium temperature. High temp packing is Grafoil packing sandwiched between two braided graphite rings	Our packing sets offer a better seal; Hex Valve standard packing sets meet EPA 1998 leak point standards.
Our stem tip design will last longer than competitors	Non-Rotating Tip Stem (NRT)	Offers tight, repeatable shutoff without the galling or cross-scoring that occurs on ball-type stems. The NRT conical stem tip stops rotating when it contacts the seat so further torque turns the stem, not the tip. Furthermore, the conical stem tip seats in the same place every time — the more often the valve is seated, the better mated it becomes with the seat. By contrast, the ball-type tip does not seat in the same place every time, as the ball tip has no consistent axis of rotation. Therefore, every time the valve seats, a new seat mark is scored on the ball tip, creating multiple potential leak paths.
Packing is adjustable, with less possibility of bonnet/body leaks	Metal-to-metal non-adjustable body-to-bonnet seal	Some bonnet designs have soft, elastomer or plastic seal rings increasing the possibility of stem leakage if excesses in temperature or pressure occur. Secondly, these other inferior designs require you to rotate the body-bonnet connection in order to access or adjust the packing. The Hex Valve body/bonnet connection is static and non-adjustable.

Primary/Orifice Block Valves

The solution to a lower cost, high temperature, rugged and compact valve installation can be found in our Hex Primary Block Valves. Produced in a variety of inlet/outlet configurations, our block valves are suitable for most petrochemical and refining applications.

- **HG65:** Orifice Block Valves are designed for compact side-by-side mounting on standard orifice flanges, condensate chambers, mercury traps, and seal traps. Two outlet ports are provided for impulse line connections or for pressure gauge or level gauge mounting. The HG65 is ideal for light hydrocarbons or utility service.



- **HG12:** The HG12 features a built-in vent or bleed screw on the outlet side of the valve. In process line mounted instrument or signal line tubing, venting or line filling capabilities can be an added feature.



- **HO25:** Features an OS&Y bolted bonnet, two outlet connections, and two outlet ports. The HO25 is more compact and has a shorter profile than the HG65 model.



Primary/Orifice Block Valves

Features and Benefits

■ Compact, Side-by-Side Mounting

The slim design of Hex primary block valves allows side-by-side mounting on standard orifice flanges, and reduces the required installation space. The shorter profile and lower weight make these valves ideal for tight installations.

■ Reduce Potential Leakage, Costs

Using Hex primary valves cuts the number of components required on traditional orifice flange installations, resulting in fewer threaded connections (fewer leak points) and lower installation costs.

■ Non-Rotating Tip (NRT) Stem

Provides tight, repeatable shutoff without galling or cross-scoring that occurs on ball type stems. The NRT conical stem tip stops rotating when it contacts the seat, so further torque turns the stem, but not the tip, preventing damage to tip.

■ New VOC Emission Compliance

Unique TFE-Chevron and high temperature 1625G/Grafoil/1625G packing designs have been certified to meet and beat the 100 ppm EPA 1998 Emission standards. Special bonnet design no longer required to meet this standard.

■ Reduce Costs & Installation Time

Use the HG65 in place of the conventional arrangement of gate valves, nipples and tees for a lower cost, easy-to-install primary valve assembly.

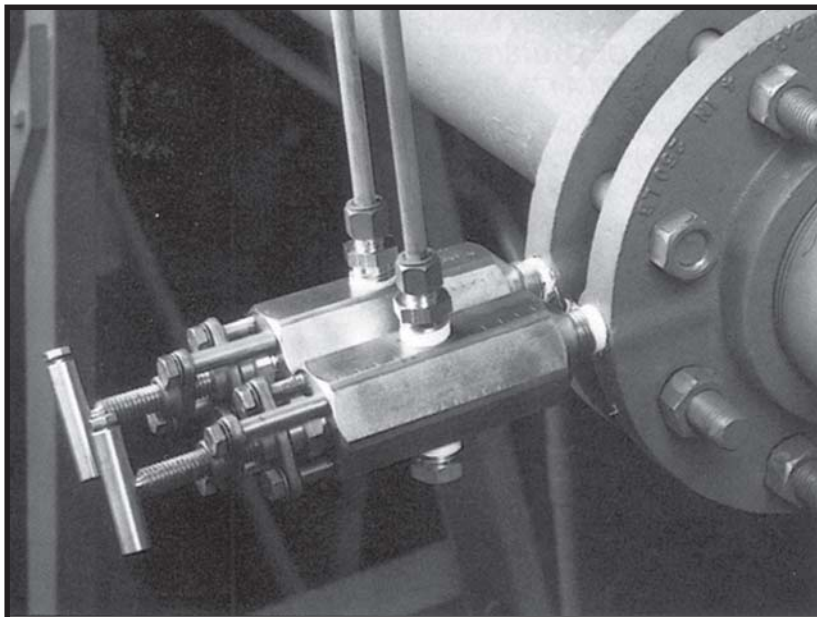

Primary/Orifice Block Valves

Dimensions

HG65

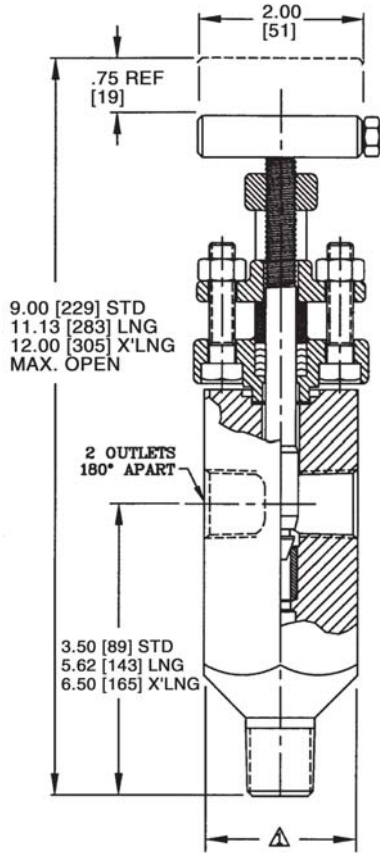

HG12

Orifice: .315"
Weight: 3.1#

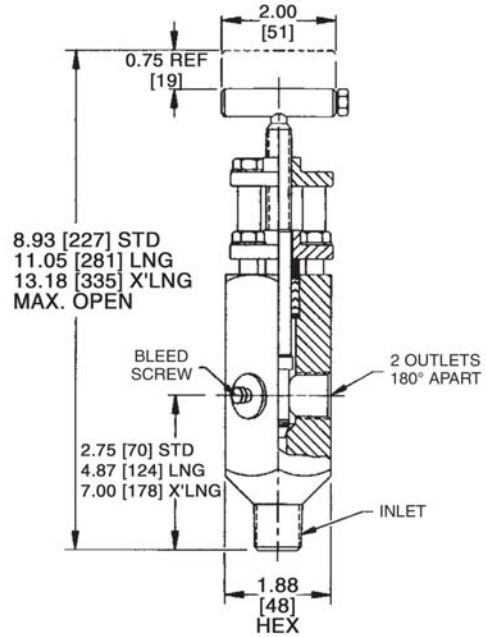

HO25

Orifice: .315"
Weight: 3.05#

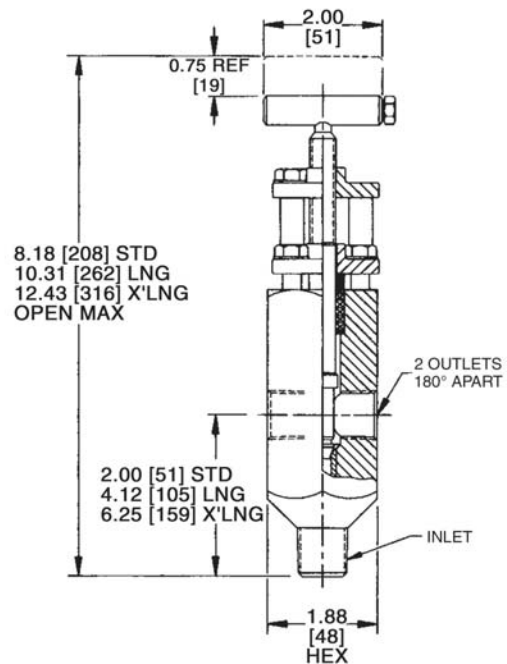

Notes:

1 Body stock size dependent upon material availability 3/8" thru 1" inlet size: 1.875 Hex or 2.00 diameter

Flow Schematic

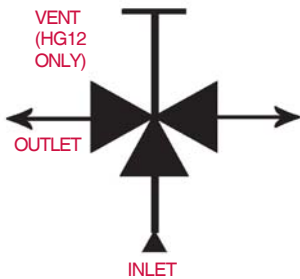

Model Numbers — Product Availability — HG65, HG12 & HO12

	HG65	1	U	3	1	3	1	4	1	2
Model Number										
HG65 HG12 HO25										
Seat/Body Configuration										
1 Hard 3 Hard, "L" Extension 5 Hard, "XL" Extension										
Body Material										
S Carbon Steel U Stainless Steel See Page 31 For Complete List										
Inlet Size										
3 1/2" 4 3/4"										
Inlet Type										
1 MNPT 2 MSW										
Outlet Size										
3 1/2"										
Outlet Type										
1 FNPT R 1 Plug A HB24										
NRT Stem Tip										
4 316 SS NRT 5 316 SS/Stellite See Page 30 For Complete List										
Seat Material										
1 Integral 2 316SS 3 Stellite See Page 30 For Complete List										
Packing										
1 Braided/Grafoil 2 TFE - Chevron 3 Graphite/Grafoil/Graphite										
Optional Items										
2 410 SS Bolting										

Gauge/Block Valves

Hex Gauge/Block Valves provide three outlet connections to facilitate the mounting of gauges and other static pressure instruments in a variety of positions. This design results in a compact installation with fewer leak points as compared to conventional mounting requirements.

- **HG46:** Compared to traditional piping methods using gate valves, tees and nipples, the HG46 provides a quick, inexpensive and compact means of installing gauges and static pressure instrumentation. The use of the HG46 also reduces the number of threaded connections, resulting in fewer potential leak points. The HG46 can be supplied with a bleed valve or needle valve threaded into one of the outlets to allow for combined block and bleed functions in a single, compact unit.



- **HG48:** The HG48 gauge/block valve provides three outlet connections to facilitate the mounting of gauges and other static pressure instruments in a variety of positions. The design creates a compact installation with fewer leak points as compared to conventional mounting requirements due to the reduced number of threaded connections. The HG46 can be supplied with an integral hard seat which matches the body material, or with a choice of soft seal materials including PPS, KEL-F, TFE, or PEEK.



- **HG47:** A roddable, hard seated orifice valve that overcomes the drawbacks of conventional valve designs. Ideal for use on high temperature, viscous services — the HG47 provides full port, unrestricted flow. The HG47 features an OS&Y bolted bonnet with weld or threaded connections. The accessible hard seat insert and non-rotating tip (NRT) stem are machined for precision fit, yet field-replaceable to allow for long service life.



Gauge/Block Valves

Ideal for use on high temperature, viscous services — the HG47 provides full port, unrestricted flow. The HG47 features an OS&Y bolted bonnet with socket weld or threaded connections. The accessible hard seat insert and non-rotating tip (NRT) stem are machined for precision fit, yet field-replaceable to allow for long service life. The Hex 47 is designed to accommodate commercially available rodding devices designed to work with products of the barstock configuration. Hex Valve, Division of Richards Industries, assumes no responsibility for the function of the rodding tool selected for any given service or application.

HG47 shown with typical rodding tool (not supplied with product)

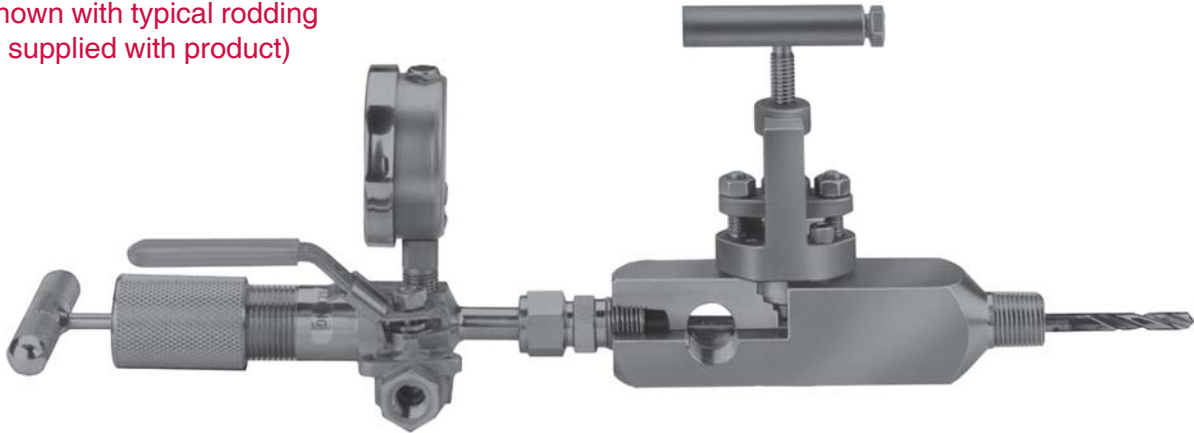

Features and Benefits

■ High Temperature, Full Ported

Use on viscous services up to 850°F. Universal 1/2" outlets allow rodding tool positioning without the removal of tubing or instrument.

■ Easy Maintenance for Long Service Life

Designed with the field technician in mind. Easy to remove non-rotating stem tip allows for easier maintenance than found with conventional valve designs.

■ Reduce Installation Time

Threads directly into the orifice flange for a quick, compact and simple installation. Conventional valving requires the lengthy and bulky installation of multiple valves, tees and nipples.

■ Reduce Potential Leakage

Using the HG46/48/47 reduces the number of threaded connections in half resulting in fewer potential leak points as compared to conventional root valve assemblies.

■ Non-Rotating Tip (NRT) Stem

Provides tight, repeatable shutoff without the galling or cross-scoring that occurs on ball type stems. Because the NRT conical stem tip stops rotating when it contacts the seat, further torque turns the stem, but not the tip, protecting the stem tip from damage.

■ Bleed and Shutoff in One Assembly

Add the optional HB Series bleed valve or an HN Series valve, and combine block and bleed functions into one single and compact unit.

Gauge/Block Valves

Dimensions

HG46

Orifice Size: 0.19"
Weight: 3.1#

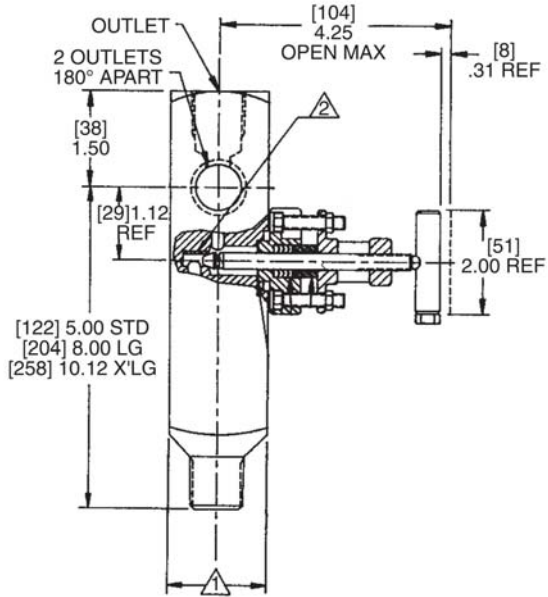

HG47

Orifice Size: 0.373" min.
Weight: 4.0#

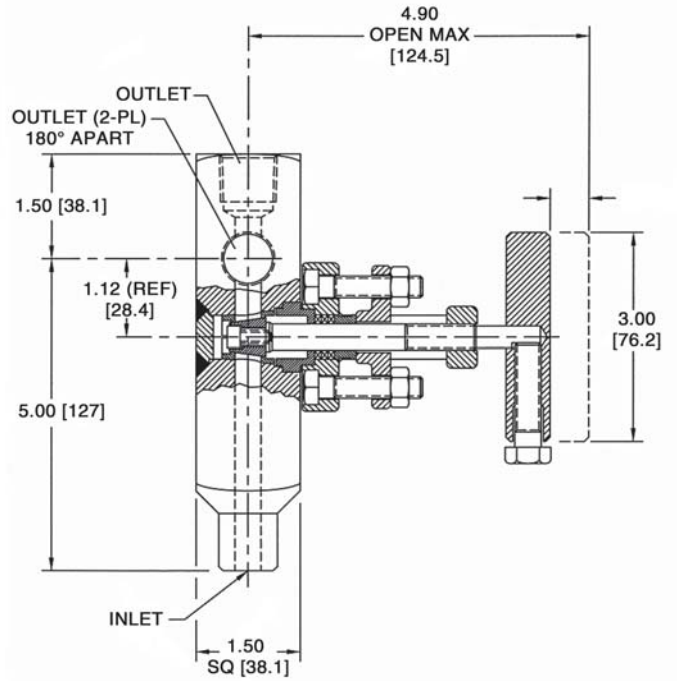

HG48

Orifice Size: 0.19"
Weight: 1.9#

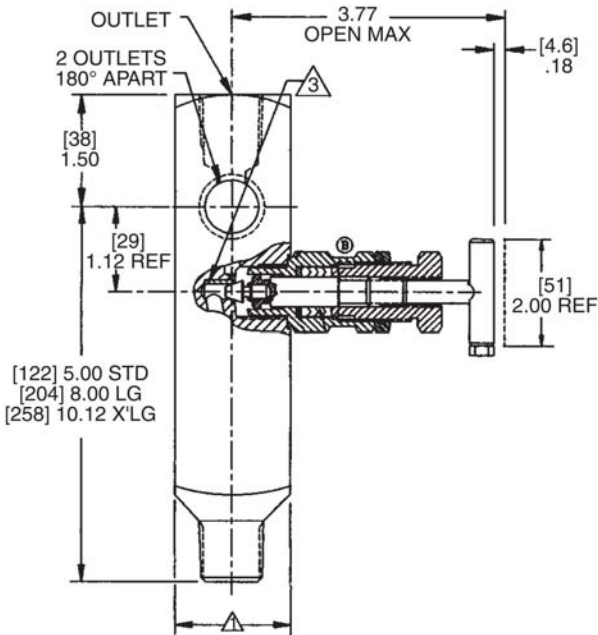

Flow Schematic

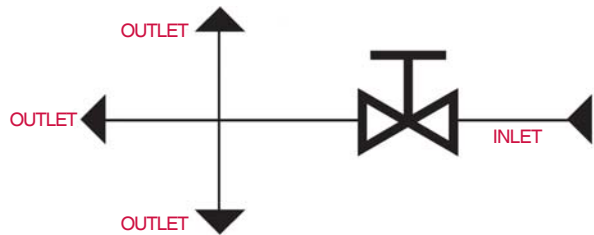

Model Numbers — Product Availability — HG46, 48 & 47

	HG46	1	S	3	3	1	1	4	1	2
Model Number										
	HG46									
	HG48									
	HG47									
Seat Configuration										
	1 Hard									
	2 Soft Seat (HG46/HG48)									
	3 Hard, "LG" Extension									
	4 Soft Seat, "LG Extension (HG46/HG48)									
	5 Hard, "XLG" Extension									
	6 Soft Seat, "XLG" Extension (HG46/HG48)									
	F Hard/O-ring (HG46/HG48)									
	G Soft/O-ring (HG46/HG48)									
Body Material										
	S Carbon Steel (A108)									
	U Stainless Steel (A108)									
	P Carbon Steel									
	See Page 31 For Complete List									
Inlet Size										
	3 1/2"									
	4 3/4"									
Inlet Type										
	1 MNPT									
	2 MSW									
	3 FNPT									
	4 FSW									
Outlet Size										
	3 1/2"									
Outlet Type										
	1 FNPT									
	A HB241									
									R Plug (1)	
									F HB241 + Plug (1)	
Stem/Tip										
	2 316 SS Needle (HG46/HG48)									
	4 316 SS NRT (HG46/HG48)									
	J 316 SS NRT/17-4 PH (HG47)									
	See Page 30 For Complete List									
Seat Material										
	1 Integral (HG46/HG48)									
	2 316 SS Insert (HG47)									
	4 PPS (HG46/HG48)									
									5 KEL-F (HG46/HG48)	
									6 TFE (HG46/HG48)	
									9 PEEK (HG46/HG48)	
Packing										
	1 Braided/Grafoil									
	2 TFE-Chevron									
	3 Graphite/Grafoil/Graphite									
	6 Viton O-ring (HG48)									
Optional Items										
	2 410 SS Bolting									

Gauge/Block Valves

The **HG35** gauge valve, with a male inlet and a male outlet, meets the application requirement for a block and bleed valve without the need for a close nipple when connecting to a female port on a gauge pressure transmitter rated to 6980 psi.

Other manufacturers generally supply 1/2" NPT female process connections and usually include a block and bleed valve with each instrument. This usually requires a 1/2" stainless steel close nipple with each gauge pressure transmitter to accommodate the typical block and bleed valve's female outlet.

The HG35 configuration provides one less threaded connection by utilizing a MALE OUTLET for direction connection into a gauge pressure transmitter.



Dimensions

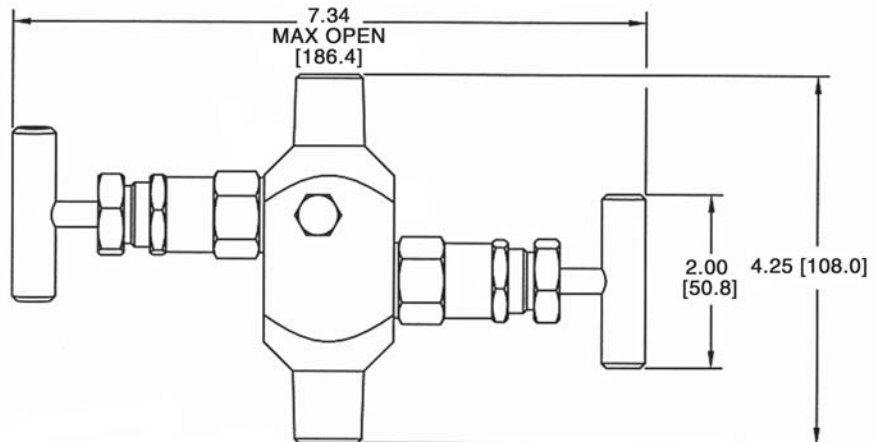
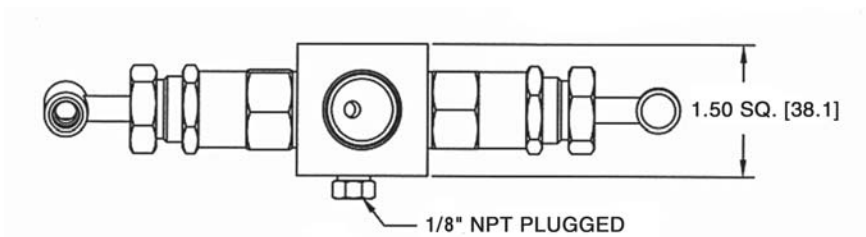

Model Numbers — Product Availability — HG35

	HG35	1	U	3	1	3	1	4	1	2
Model Number	HG35									
Seat Configuration	1 Hard									
Body Material	S Carbon Steel U Stainless Steel See Page 31 For Complete List									
Inlet Size	3 1/2"									
Inlet Type	1 MNPT									
Outlet Size	3 1/2"									
Outlet Type	7 MNPT									
Stem/Tip	4 316 SS NRT									
Seat Material	1 Integral									
Packing	1 Braided/Grafoil 2 TFE - Chevron 3 Graphite/Grafoil/Graphite									

Block & Bleed Valves

Like all Hex products, the philosophy behind block and bleed valve products is to simplify the piping associated with gauge pressure installations. Traditional assemblies utilize multiple connections and may not offer the convenience of both vent and calibration facilities. The Hex arrangement can replace multiple components and offer fewer potential leak points at the same time. The customer will reduce the space required for installation (thereby lowering the potential for hazard), and save on installation time and overall costs.

■ **HB50 Block & Bleed Valves:** The HB50 features a fully packed and backseated block valve along with a bleed valve with directional discharge tube and stem stop. With a gauge or transmitter threaded into its outlet, the HB50 will allow pressure to be bled and blocked for simplified instrument removal. The discharge tube enables the technician to direct the high pressure fluid away from himself before changing the instrument. The HB50 can also be threaded into a Hex Primary Block Valve (such as the Hex HG46) to provide secondary block and bleed functions on multiple instrument installations.



■ **HB51 Block & Bleed Valves:** The HB51 is similar to the HB50 but utilizes a bleed screw in lieu of a bleed valve.

■ **HB52 Bleed Tee:** The Hex HB52 Bleed Tee is ideal for modernizing outdated, non-bleed gauge installations. During instrument maintenance, simply thread the HB52 into the outlet of an existing block valve. An instrument is then threaded into the HB52 outlet to complete the installation. A second 1/2" side outlet accommodates a gauge or tube fitting for a remote auxiliary instrument. Bleed-off is simple — a turn of the handle directs flow through the discharge tube.



■ **HB59 Integral Block & Bleed Valves:** For more critical services, the HB59 Integral Block & Bleed Valve combines a fully packed backseated block valve and a fully packed backseated bleed valve into a single, streamlined assembly that minimizes threaded connections. A major benefit of this design is that, while minimizing connections, cost and installation time are also reduced. A 1/2" FNPT adaptor can accommodate a tube fitting for remote removal of bleed waste. The HB59 is typically used on applications where waste must be returned to the line or holding vessel, as is common with hazardous media or EPA-targeted hydrocarbons.



Block & Bleed Valves

■ **HB24/25/26/27 Bleed Valves:** The HB24/25/26/27 Series Bleed Valves are available individually, or optionally threaded into an unused outlet port on a variety of Hex Valve models. Used for bleeding off high pressure media, the HB24 & HB25 incorporate back-out stops to prevent inadvertent removal of the stem; the HB26 does not include this feature to allow for stem removal to facilitate calibration through the valve.

- HB24: features an easy to use “T” handle plus directional discharge/drain/tube.
- HB25: incorporates a “hex” head screw to reduce tampering, and also supplies a directional discharge tube.
- HB26: features a “hex” head screw, but no discharge/drain tube.
- HB27: Incorporates a “Mini-Bonnet” (packed) assembly with discharge/drain tube

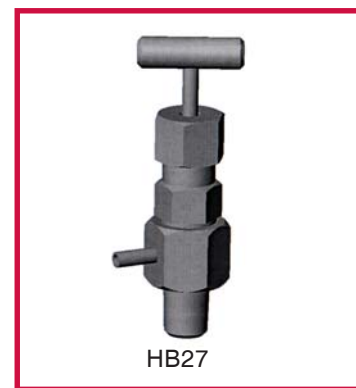
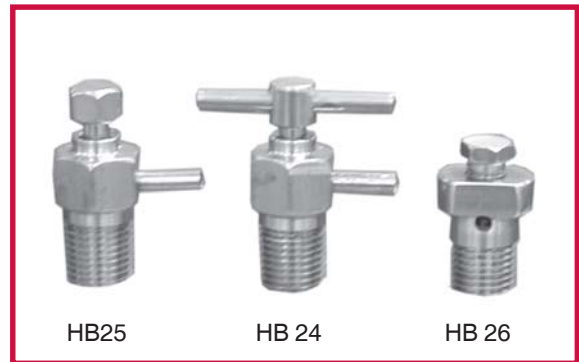

Features and Benefits

■ Reduce Costs and Installation Time

Conventional instrument piping requires a costly arrangement of valves, nipples, and fittings that can be streamlined into a single valve assembly. Hex block & bleed valves minimize threaded connections while combining multiple valve functions. You will achieve tight shutoff and bleed capabilities in one compact assembly while reducing installation time, labor costs, and space requirements while lowering overall piping costs.

■ Fully Backseated Bonnets (HB50/59)

Prevent accidental stem removal and blowout. The unique design of our fully backseated bonnets minimizes emissions.

■ Non-Rotating Tip (NRT) Stem (HB50/59)

Provides tight, repeatable shutoff without the galling or cross-scoring that occurs on ball type stems. Because the NRT conical stem tip stops rotating when it contacts the seat, further torque turns the stem, but not the tip, protecting the tip from damage.

Block & Bleed Valves

Dimensions

HB50/51

Orifice Size: 0.19"
Weight: 1.81 #

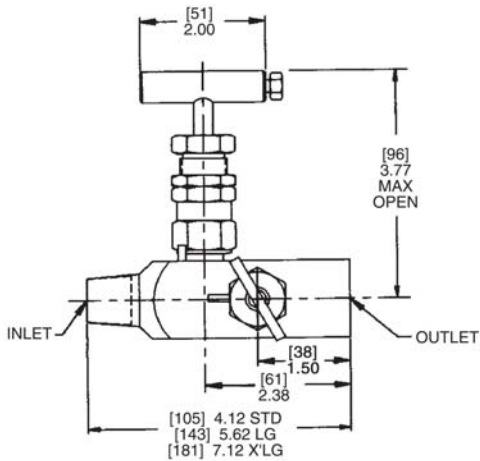
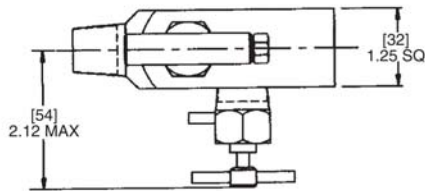

HB59

Orifice Size: 0.19"
Weight: 2.75 #

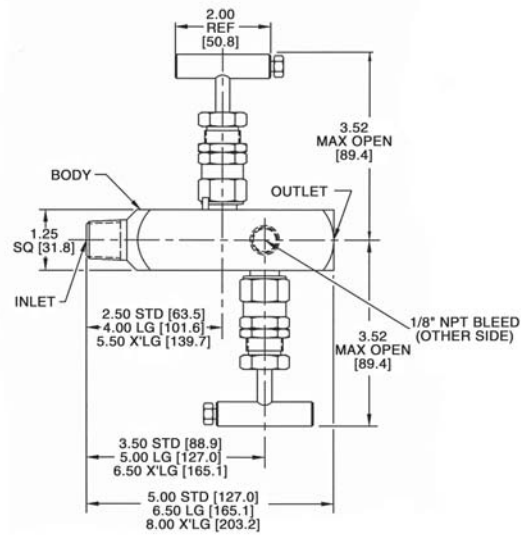
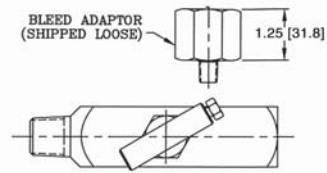

HB52

Orifice Size: .315"
with .127" bleed
Weight: 1.5 #

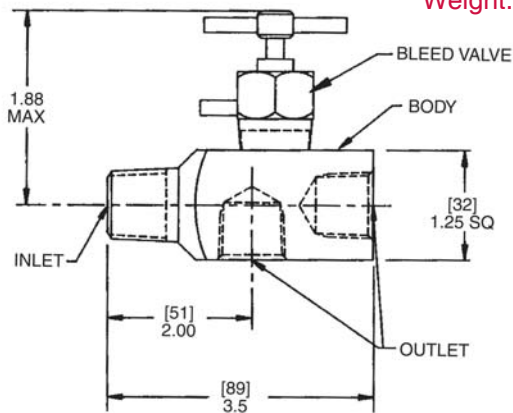

HB24/25/26/27

- Orifice: .127" bleed
- Maximum weight: 0.25#

Flow Schematics

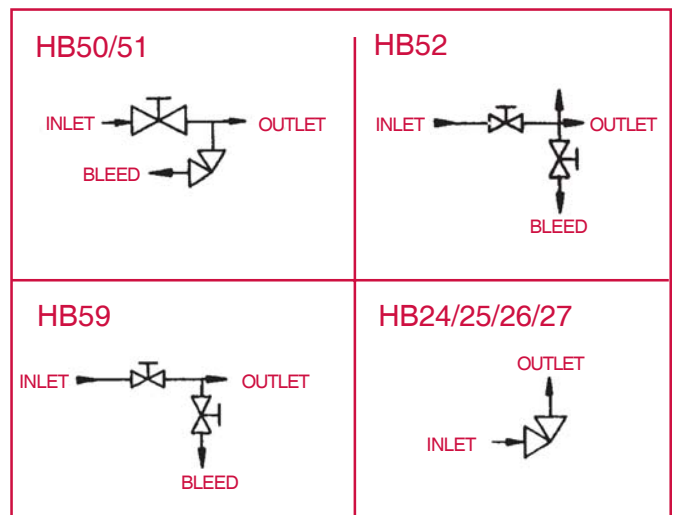

Model Numbers — Product Availability — HB50, 51 & 59

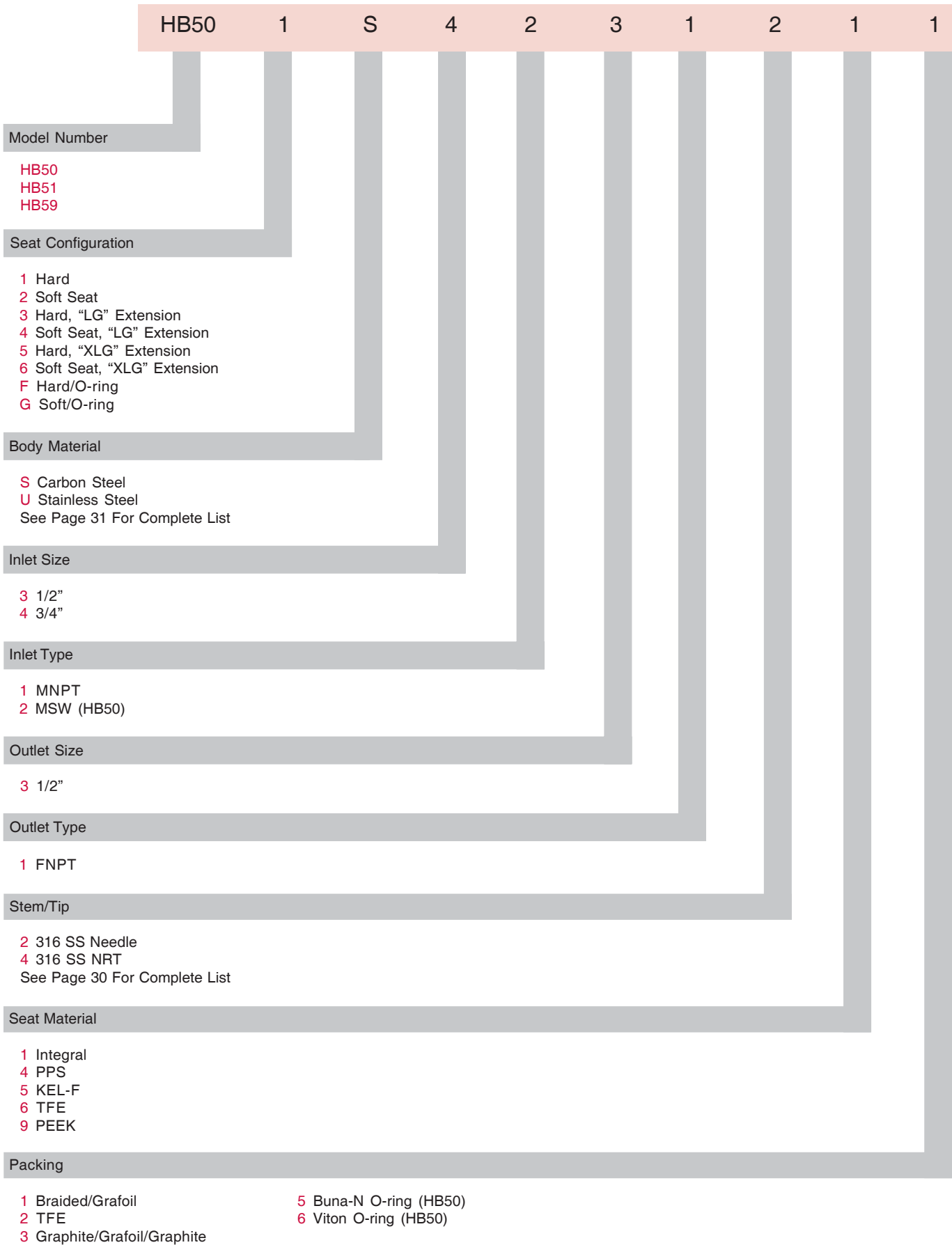

Model Numbers — Product Availability — HB52

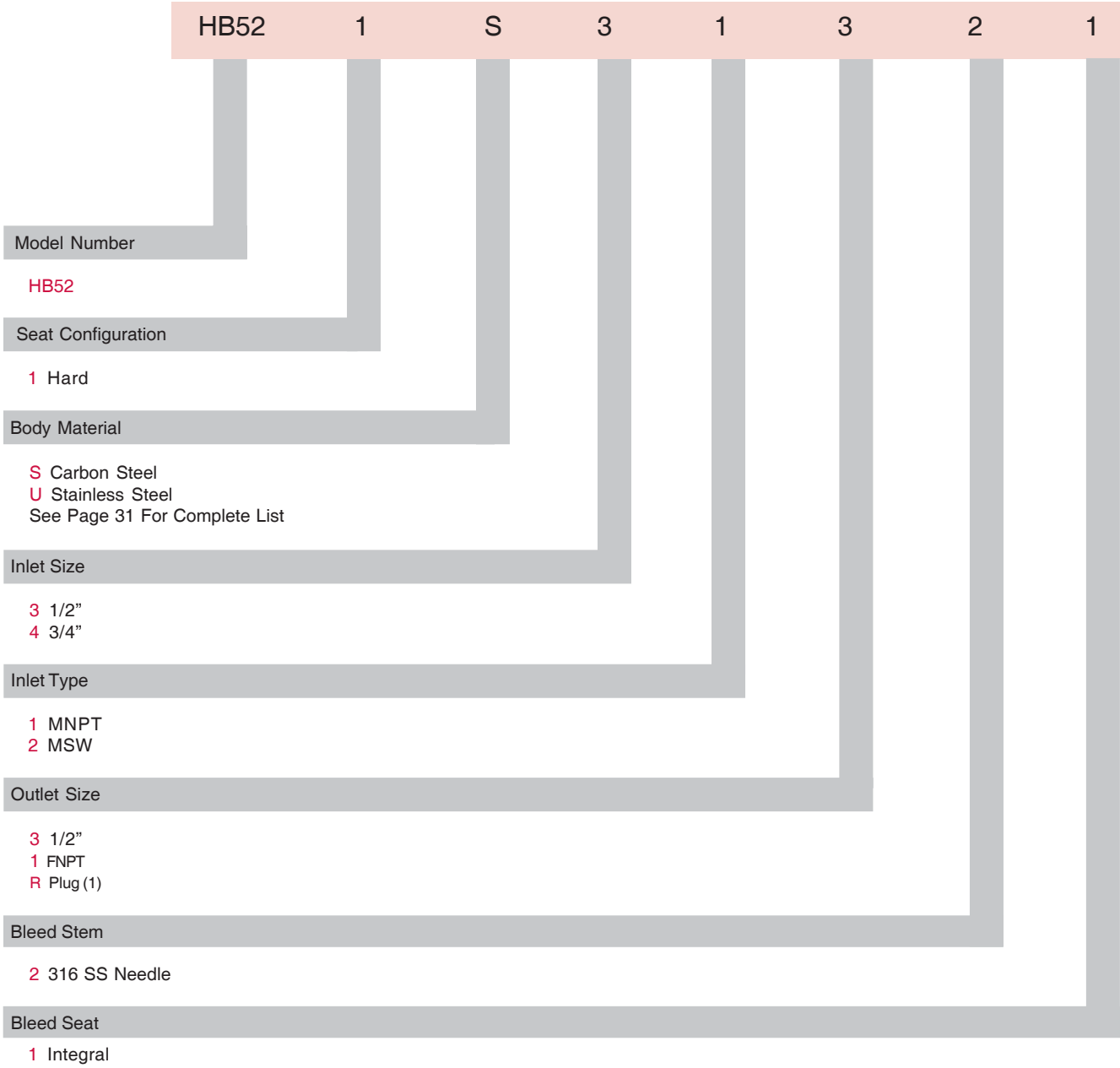

Model Numbers — Product Availability — HB24/25/26/27

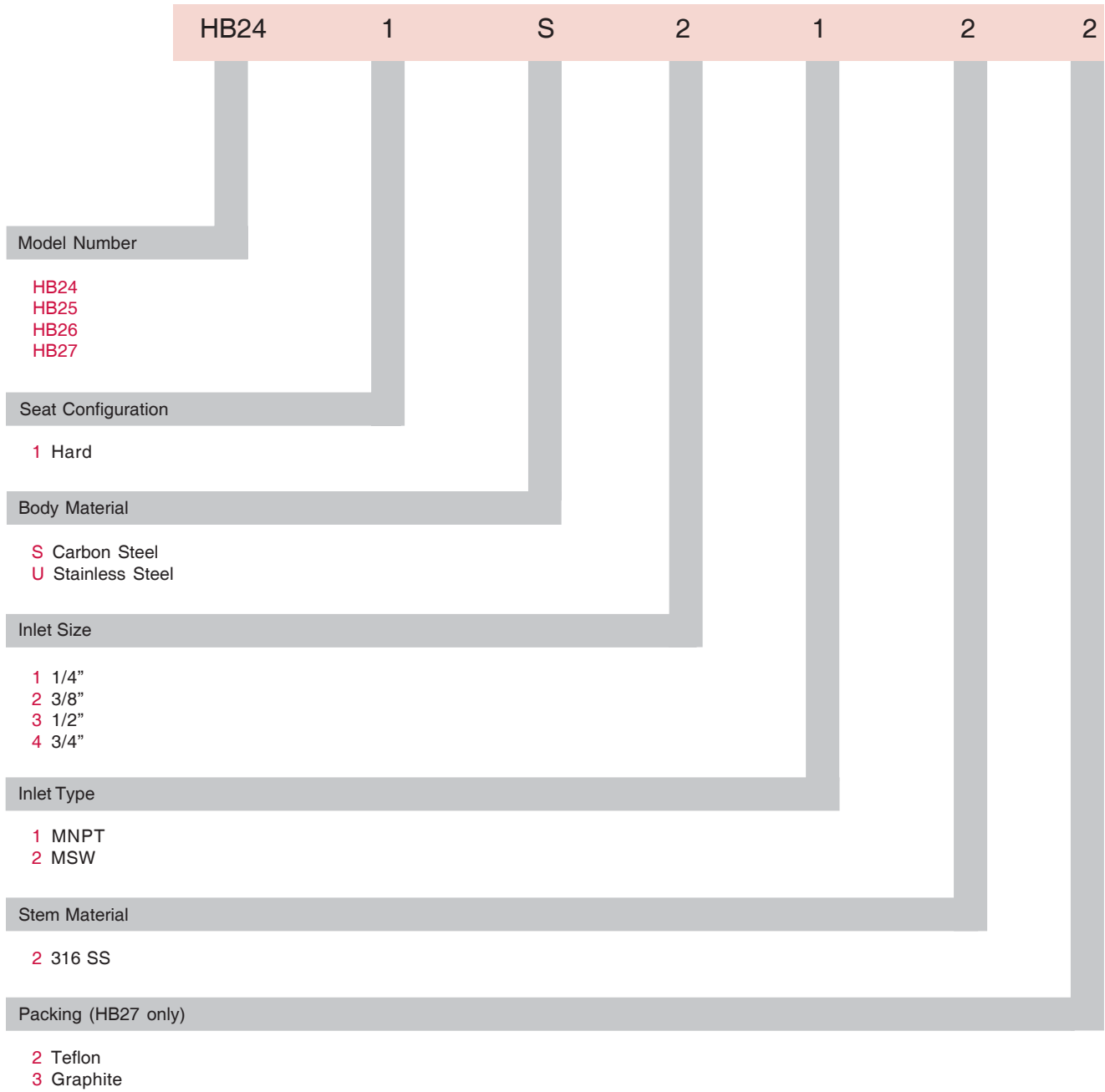

Gauge Syphons

Syphons For Steam And Heat Transfer Media

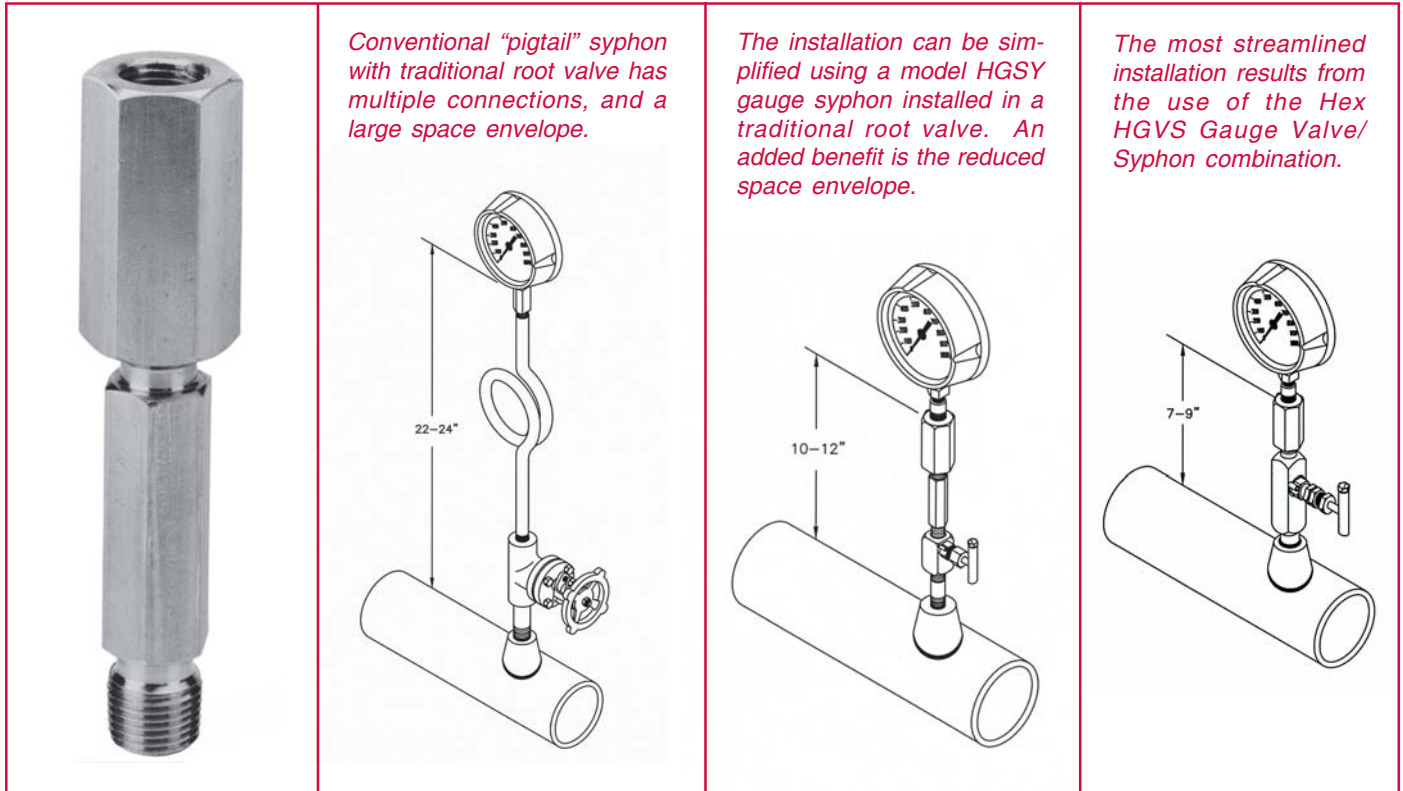

Hex gauge syphons act as thermal and liquid seal barriers between hot process vapors (such as steam and heat transfer fluids) and the gauge pressure instrument. It is designed to replace the large installation space requirements of the traditional "pigtail" syphon, providing maximum instrument protection in half the space. This reduced radius minimizes weight and deflection stress at the primary valve.

Features and Benefits

■ Minimizes Space/Radius Requirements

Using a model HGSY syphon and a Hex "male x female" globe/needle valve can reduce the conventional installation radius by 50%. Using the model HGVS combination valve and syphon reduces the radius an additional 15%.

■ Minimizes Deflection Stress

Both models minimize deflection stress at the primary valve connection as a result of reduced weight and radius, decreasing problems associated with system vibration.

■ Thermal Protection

Whether high process temperature or instrument freeze-up are concerns, both models provide a constant thermal barrier. A liquid barrier is always present between the instrument and syphon to minimize overheating. For freeze protection, simply fill the syphon with a process-compatible liquid fill.

■ Leak Point Minimization

Utilizing the model HGVS syphon with a welded connection reduces threaded connections from four to two.

Gauge Syphons

Dimensions

Model HGVS

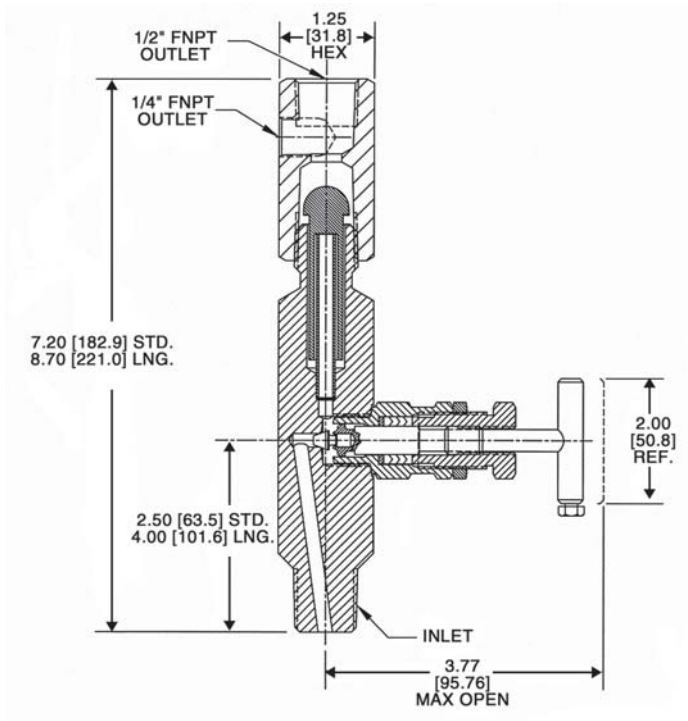

Model HGSY

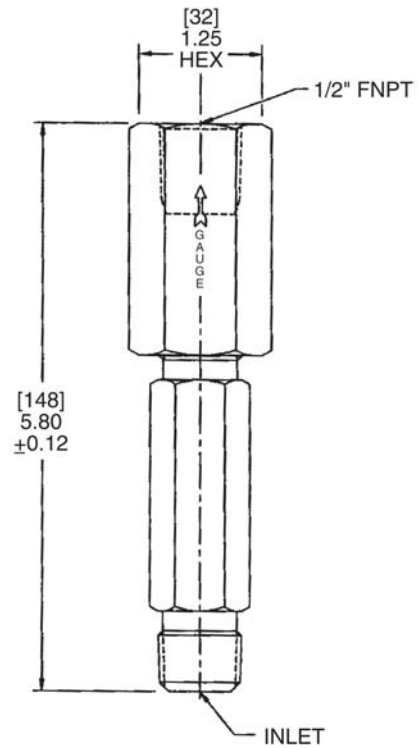

Flow Schematic (Model HGVS)

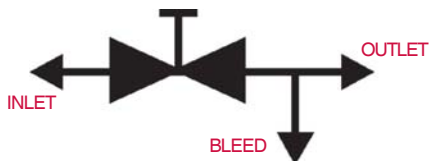

Model Numbers — Product Availability — HGVS & HGSY

	HGVS	1	S	3	1	3	1	4	1	2
Model Number										
HGVS HGSY										
Hard Seat/Body										
1 Standard Body 3 Long Body (HGVS)										
Body Material										
S Carbon Steel U Stainless Steel See Page 31 For Complete List										
Inlet Size										
3 1/2" FNPT 4 3/4" FNPT										
Inlet Type										
1 MNPT 2 MSW										
Outlet Size										
3 1/2"										
Outlet Type										
1 FNPT A HB241 in side (HGVS) R Plug (1) in side (HGVS) E HN49 in side (HGVS) V HB27 in side (HGVS)										
Stem/Tip (HGVS)										
4 316 SS										
Seat (HGVS)										
1 Integral										
Packing (HGVS)										
1 Braided/Grafoil 2 TFE-Chevron 3 Graphite/Grafoil/Graphite										

Sample/Drain Valves

The **HS31** is a sample/drain valve used to extract a fresh sample while providing tight shutoff and high pressure and temperature capabilities. It is designed as a solution to routine and difficult fluid sampling applications including viscous liquids, slurries and products that tend to solidify when cooled or exposed to the atmosphere.

The HS31 design features a reciprocating stem that unplugs the sample section as it opens. Opening the valve moves the plunger into the pipeline or vessel to remove any debris or sediment, assuring that a fresh sample enters the valve body. The valve also features two standard outlet ports. This allows the user to thread a sample cylinder, tube fitting, or piping into one outlet while using the additional outlet for check valve or bleed valve installation, clean-out or purging connections.

For shutoff considerations, the HS31 can be provided with metal-to-metal seats or optional dual seating. The dual seat consists of a retained KEL-F seat installed in the inlet end of the valve body, backed up by a secondary metal-to-metal seat directly downstream.



Features and Benefits

■ Wide Material Selection Suits a Variety of Applications and Services

Barstock body available in a large selection of materials including Carbon Steel, Stainless Steel, Monel, Alloy 20, Hastelloy B, and Hastelloy C.

■ Reciprocating Stem

Opening the HS31 moves the plunger into the pipeline or vessel to remove any debris or settlement. This allows a fresh sample to enter the valve body.

■ Dual Seating Option

The HS31 is available with metal-to-metal seats or optional dual seating. The dual seat consists of a retained Kel-F seat installed in the inlet end of the valve body, backed up by a secondary metal-to-metal seat directly downstream.

■ Two Outlet Ports Standard

A sample cylinder, tube fitting, or piping is threaded into one outlet, with an additional outlet provided for check valve or bleed valve installation, clean-out or purging connections.

Model Numbers — Product Availability — HS31

	HS31	1	U	5	1	9	1	2	1	2
Model Number	HS31									
Seat Configuration	<ul style="list-style-type: none"> 1 Hard Seat 2 Soft Seat 									
Body Material	<ul style="list-style-type: none"> S Carbon Steel U Stainless Steel See Page 31 For Complete List									
Inlet Size	<ul style="list-style-type: none"> 4 3/4" 5 1" 6 1-1/2" 									
Inlet Type	<ul style="list-style-type: none"> 1 MNPT 2 MSW 									
Outlet Size	<ul style="list-style-type: none"> 3 1/2" x 1/2" 4 3/4" x 3/4" 9 1/2" x 3/4" 									
Outlet Type	<ul style="list-style-type: none"> 1 FNPT A HB241 R Plug (1) S Plugs (2) 									
Stem Material	<ul style="list-style-type: none"> 2 316 SS 									
Seat Material	<ul style="list-style-type: none"> 1 Integral 2 316 SS 5 KEL-F Soft 									
Packing	<ul style="list-style-type: none"> 1 Braided/Grafoil 2 TFE-Chevron 3 Graphite/Grafoil/Graphite 									

Sample/Drain Valves

Dimensions

HS31

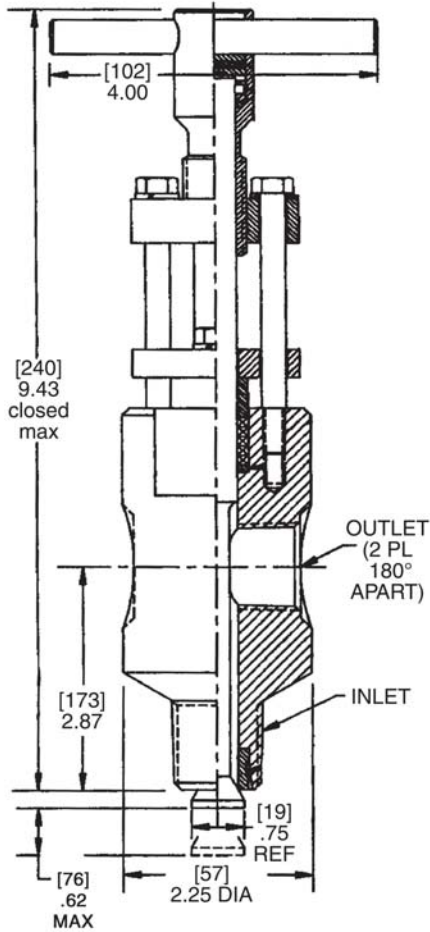

Weight: 5.5#
Hard Seat Orifice: 0.628"
Soft Seat Orifice: 0.500"

Seat Configurations



Metal-to-Metal Seating
(Insert Shown)



Dual Seating

Flow Schematic

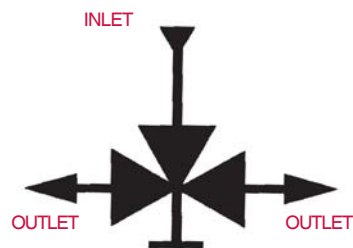

High Temperature Valves

High Temperature Valves

Hex HT03 and HT01 high temperature globe valves are designed for service to 1500°F at 500 psi working pressure. They are available in sizes up to 1-1/2" with NPT, socket weld, butt weld or flanged end connections.

Hex high temperature valves are used as shutoff or block valves, as well as bleed valves on hydrogen scrubbers, compressors and in hydrocracking units.



Dimensions

HT01 Series

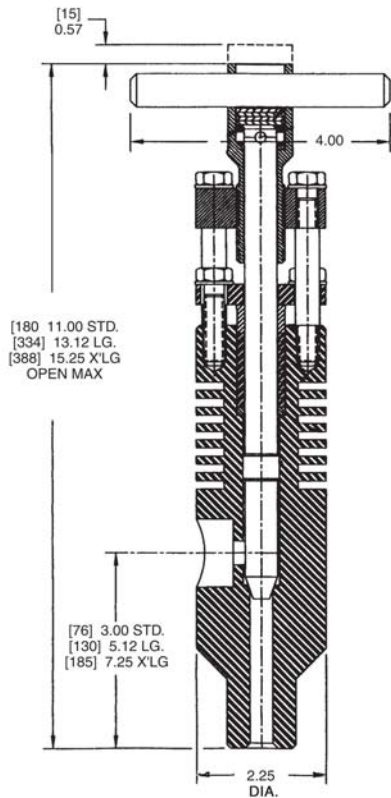

HT03 Series

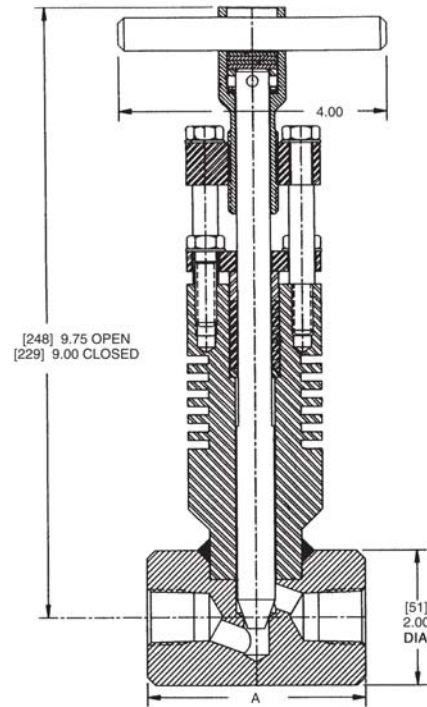

Flow Schematic



Inlet	Outlet	A	Inlet	Outlet	A
1/2 FPT	1/2 FPT	3.25"	3/4" MSW	1/2 FPT	3.25"
1/2 MPT	1/2 FPT	4.00"	3/4 MSW	1/2 FPT	4.00"
1/2 FSW	1/2 FSW	3.00"	3/4 FPT	3/4 FPT	3.81"
			3/4" FSW	3/4 FSW	3.00"

Model Numbers — Product Availability — HT01 & HT03

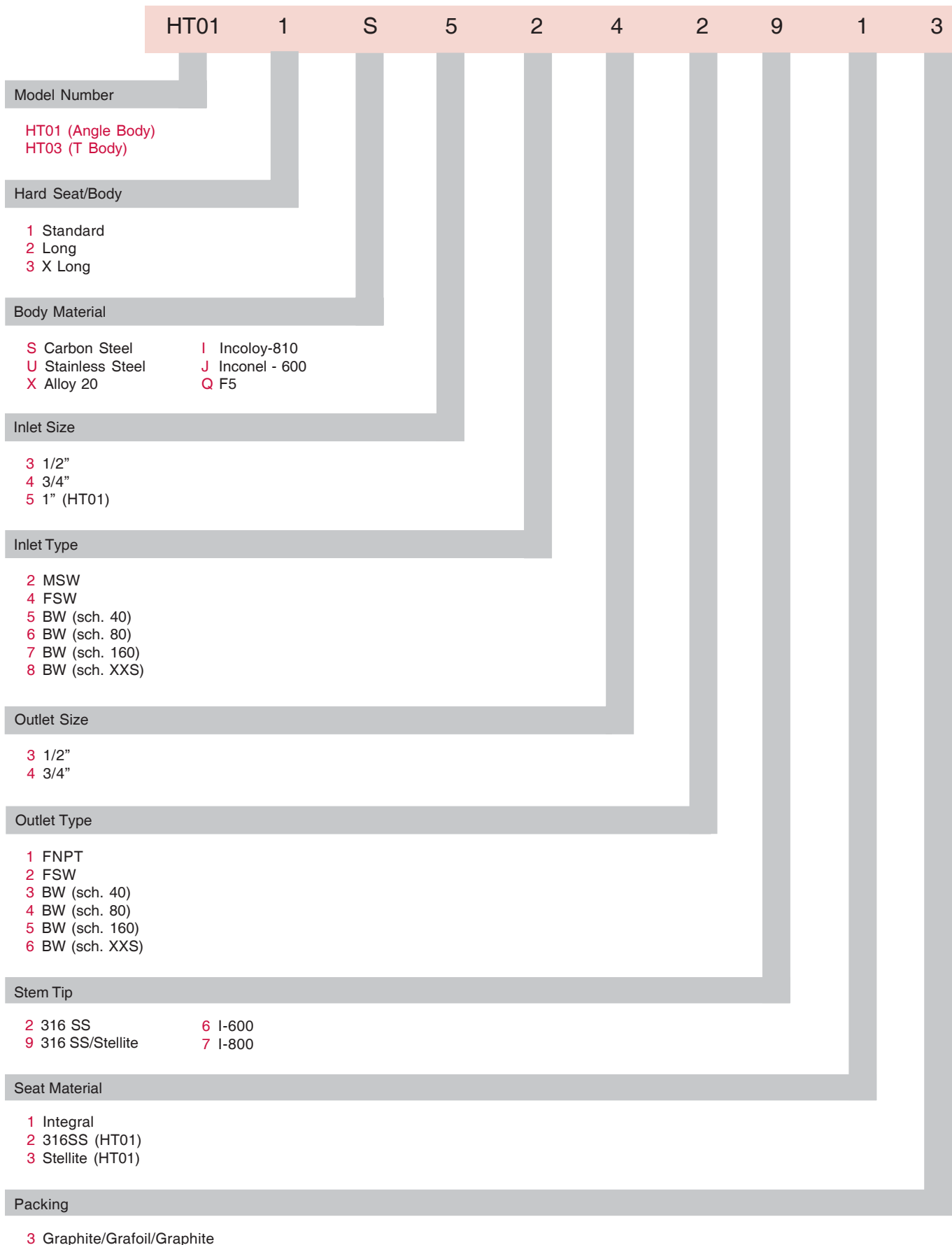

Bellows Stem Seal Option



Hex Valve offers a bellows stem seal option for use on Hex instrument valves in the control and monitoring of corrosive chemicals, hazardous materials or any application where leakage and containment are primary considerations.

The bellows stem seal option can be specified on a wide range of Hex instrument valves, gauge valves, bleed valves, three and five valve manifolds and static pressure manifolds. The bellows is hydroformed and laser-welded to the stem assembly for greater stability and longer life.

The bellows can be provided in either 316L or Monel, and the option also provides secondary sealing for greater protection than can be achieved with a single seal design. Hex Valve exercised care in maintaining compact bonnet dimensions to reduce the risk of accidental breakage or damage to the bellows and also to reduce the amount of space that would be required to install the products.

Features and Benefits

■ Non-Rotating Tip (NRT) Stem

Provides tight, repeatable shutoff without the galling or cross-scoring that occurs on ball type stems. The NRT conical stem tip stops rotating when it contacts the seat, so further torque turns the stem, but not the tip, preventing damage to the tip.

■ Optional Seal Welding

Fillet welds covering all joined external components can be specified as an option.

■ Back-Up Sealing

Secondary sealing for greater protection against leakage than provided by single seal designs. Available with o-ring or packed seal on hard seated models.

■ Bellows Option Available on a Wide Selection of Models

The bellows stem seal option can be provided on Hex instrument valves, primary gauge or block valves, bleed valves, three valve manifolds and static pressure manifolds.

Bellows Stem Seal Option

Ordering Information

The Hex Bellows Stem Seal option provides a bellows produced in 316L Stainless Steel or Monel. The bellows option is available on these Hex Valve models:

Primary Block (Root Valves)

- HG461
- HG465

Instrument Valves

- HG48
- HN49
- HB50
- HB59

How To Order

Hex Bellows Stem Seal valves are easy to order. From the bellows option shown below, add the appropriate digits to the end of your specific valve model number.

- Multi-ply bellows: add "RD"
- Multi-ply, seal-welded assembly: add "RE"
(Note: seal-welded assemblies are available only on hard seated models)

Dimensions

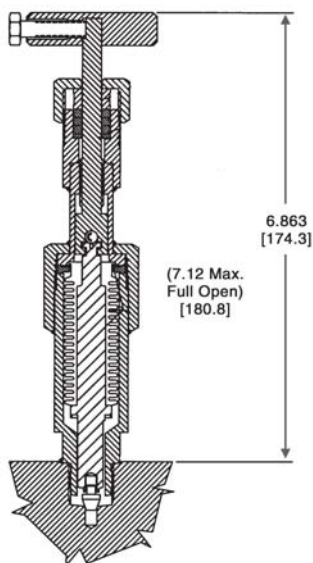

Bellows Seat Bonnet

Pressure/Temperature Ratings

The Ratings shown are for 316L SST bellows only, and assumes 15,000 to 30,000 cycle life. Individual valve ratings should be considered in final evaluation, and can be found on the *Hex Pressure/Temperature Charts* available from our factory and representatives.

Temperature, °F	Pressure, PSIG
-20 to 100	1500
200	1410
300	1320
400	1245
500**	1170
600**	1110
650**	1075***
700**	1050
800**	990
900**	930
1000**	900

** Requires high temperature secondary seal.

***Carbon Steel temperature limit.

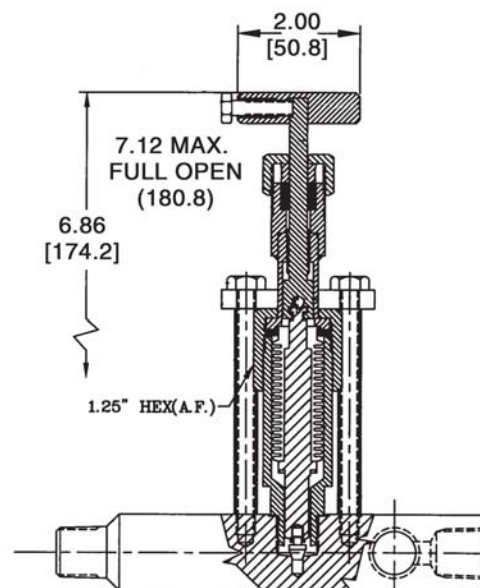

HG46 Bellows Seal Bonnet (Packed Sec. Seal)

Pressure/Temperature Ratings

Determining Hex Valve Pressure and Temperature Ratings

1. **From the chart on the right, determine the proper curve (on page 29) to use based on:**

- Carbon Steel or Stainless Steel body material
- Hard Seat or Soft Seat

2. **What stem packing is required?**

The stem packing will determine the maximum service temperature in hard seated valves. The shaded areas of the curve indicate the maximum service temperature for the various packings. (With soft seated valves, the soft seat material determines the maximum service temperature).

3. **Determine the initial ratings.**

Refer to tables on Page 29. The column headed by the curve letter (determined in step 1) will show the maximum pressure at 100°F (37.78°C) and following the column down to the maximum temperature (determined in step 2) will show the pressure rating at this maximum temperature.

4. **Check the notes on page 29 to see if any modification may be necessary due to:**

Valves made in special material or to specifications such as NACE MR-01-75 which may change the standard rating.

- Corrosion allowance
- Code limitations
- Buttweld end connections
- Flanges or unions having ratings less than the valve rating
- Materials for temperature over 1000°F (537.78°C).

5. **Consult appropriate curve for precise pressure/temperature ratings.**

6. **The low temperature limits on the standard materials are:**

- Carbon Steel: -20°F (-28.89°C)
- Stainless Steel: -450°F (-267.78°C)
- Grafoil Seals: -400°F (-240.00°C)
- Teflon Seals: -120°F (-84.44°C)
- Viton Seals: -20°F (-28.89°C)

Hard Seated Valves

- Consult curve listed under material

Valve Model	Carbon Steel	Stainless Steel
HA162	B	C
HB241	B	C
HB251	B	C
HB261	B	C
HB501	B	C
HB521	B	C
HB591	B	C
HE361	B	C
HE401	B	C
HE441	B	C
HG121	B	C
HG35	B	C
HG461	B	C
HG481	A	C
HG651	B	C
HM131	B	C
HM141	B	C
HM401	B	C
HM451	B	C
HM461	B	C
HM501	B	C
HM531	B	C
HM541	B	C
HM551	B	C
HM561	B	C
HM571	A	C
HM581	B	C
HM591	B	C
HM881	B	C
HN491	B	C
HO251	B	C
HO501	B	C
HO521	B	C
HS311*	B	C
HS311**	F	G
HT011	—	C
HT031	—	C
HT101	—	C

*INTEGRAL SEAT

**HARD SEAT INSERT

Soft Seated Valves

- CTFE (KEL-F), TFE Seats: use curve H
- PPS (Polyphenylene Sulfide): use curve J
- PEEK (Polyetheretherketone): use curve K
- Acetal: use curve N
- Exception: HR532 with Viton seats: use curve M

Pressure/Temperature Ratings

Tabular Values of Rating Curves, PSIG

Temperature	A	B	C	F	G	H	J	K	M
-20 to 100°F	6185	6580	6980	3100	3100	1500	4000	4500	2500
200°F	5640	6000	6000	3050	3050	500	1000	3565	1000
300°F	5300	5420	5420	3000	3000		500	2635	500
400°F	4975	4975	4975	2900	2900			1700	
450°F	4800	4800	4800	2875	2875			1235	
500°F	4630	4630	4630	2850	2850			1000 @	
600°F	4370	4370	4370	2750	2750			475°F	
650°F	4300	4300	4300	2700	2700			limit	
700°F			4185		2550				
750°F			4095		2525				
800°F			4025		2500				
850°F			3860		2425				
900°F			3815		2350				
950°F			3745		2250				
1000°F			3525		2150				

To determine rating from curve:

- Refer to the table on Page 28 and determine corresponding curve for your specific model and body material.
- Enter the chart below at desired temperature and follow up to the appropriate curve.
- At intersection of curve and temperature, follow to left to maximum allowable pressure at selected temperature.

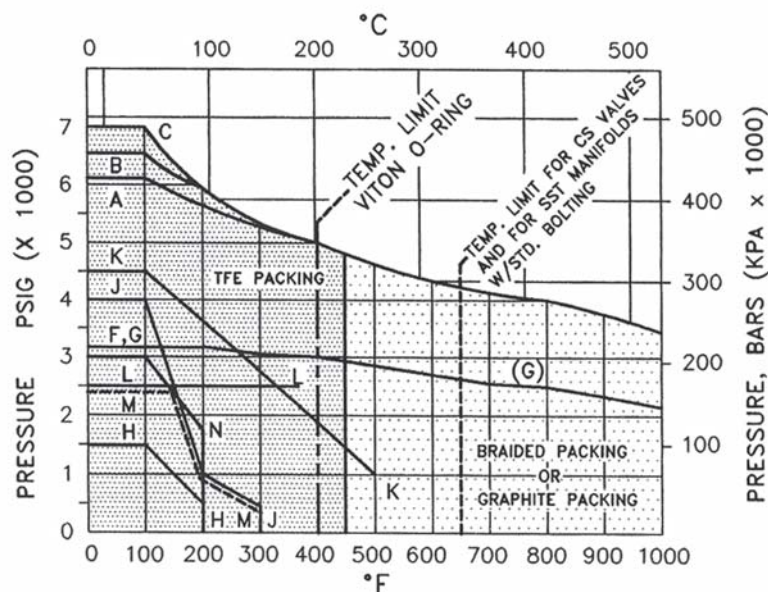





Notes

- Carbon Steel is 1018/1020 and ASTM A216, Gr. WCB. Stainless Steel is ASTM A479, Type 316 and ASTM A351, Gr. CF8M.
- For valves supplied to meet NACE MR-01-75, contact factory for rating.
- For other materials, contact factory.
- Rating basis is a factor of safety of 4:1 on pressure containing parts and 2:1 for packing or seal leakage.
- No corrosion allowance has been made.
- Consult codes, where applicable, on limits of tapered pipe thread connections.
- Ratings shown are for valves with pipe thread, socket weld or SAE straight thread inlets/outlets. For other end connections, consult factory for rating.
- Standard bolting for all manifold valve flanges is SAE Gr. 8, to 650°F. Contact factory for special bolting for higher temperatures.
- For services above 450°F, specify high temperature packing options. Grafoil flange gaskets are standard when high temperature packing is selected.
- For services above 1000°F, contact factory for special materials.

Stem/Seat Configurations

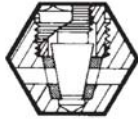
Seat and Tip Matrix

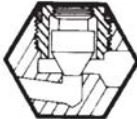
Model Number	Seat Selection					Stem Tips	
	Soft	Soft	Hard Insert	Hard Insert	Hard Integral	NRT	Needle
Roddable	No	Yes	Yes	No	No		
HG12				X	X	X	X
HG25				X	X	X	X
HG65				X	X	X	X
HG46		X		X	X	X	X
HG47			X			X	
HG48		X			X	X	X
HG35					X	X	
HGVS					X	X	X
HB50		X			X	X	X
HB52					X		X
HB59		X			X	X	X

					
---	---	---	---	---	---

Steam/Seat Configuration

Body Material Matrix

Model Number	Carbon Steel	Stainless Steel	Monel	Hastelloy C	Hastelloy B	Alloy 20	Carbon Steel, NACE	Stainless Steel, NACE	Inconel 600	Incoloy 800
HG12	1	2	3		4	5	X	X	6	7
HG25	1	2	3		4	5	X	X	6	
HG65	1	2	3		4	5	X	X	6	
HG46/48	1	2	3	8	4	5	X	X	6	7
HG47	9	2					X	X		
HG35	1	2					X	X		
HGVS	1	2					X	X		
HB50	1	2	3	8	4	5	X		6	7
HB52	1	2	3	8	4	5	X		6	7
HB59	1	2	3	8	4	5	X		6	7
HS31	1	2	3	8	4	5			6	7

Material Codes

Number	Material	Specification
1	Carbon	ASTM SA108, Gr. C1018/1020
2	Stainless	ASTM SA479, 31600
3	Monel	ASTM B164
4	Hastelloy B	ASTM B335
5	Alloy 20	ASTM B473
6	Inconel 600	ASTM B166

Number	Material	Specification
7	Incoloy 800	ASTM B408
8	HastelloyC	ASTM B574
9	Carbon	ASTM SA105
10	Carbon	ASTM SA216, WCB
11	Stainless	ASTM SA351 CF8M, Gr. 316

Notes:

1 NACE Valves in accordance with MR-01-75

NACE Specifications

Sour service covers hydrocarbons, notably petroleum crudes and gases containing sulfur in the form of hydrogen sulfide (H₂S). The corrosion phenomenon causing concern is referred to as sulfide stress cracking (SSC). Most ferrous metals, when hardened by heat treatment or cold working to hardness above Rc22, are susceptible to sulfide stress cracking when exposed under stress to a sour environment.

Equipment used in instrument systems operating in sour gas service will require conformity to the NACE (National Association of Corrosion Engineers) Standard MR-01-75.

General Requirements:

- Carbon and low alloy steel shall not be harder than Rc22 in the finished condition, and must be either hot rolled, annealed, normalized, quenched and tempered, or stress relieved.
- Free machining steels shall not be used.
- Low and medium alloy steels containing less than 12% chromium and/or more than 1% nickel shall not be used.
- Inconel shall not be harder than Rc35 in the finished condition.
- K-Monel shall not be harder than Rc32 in the finished condition, and must be age hardened or solution annealed.
- Carbon Steel bolting shall conform to ASTM A-193, grade B-7M, and ASTM A-194, grade 2HM specifications. Pressure-containing bolting shall conform to sour gas requirements specified in above points whether they contact the sour service or not.

VOC Emissions

In evaluations by an independent valve testing laboratory, as witnessed by a major U.S. refinery, Hex Valve has certified that its valve stem packing designs now adhere to the stringent EPA requirements for VOC emissions of less than 100 ppm.

The tests were performed using EPA Reference Method 21 (reference: 40 CFR 60), BAAQMD Reg. 8, Rule 18, SCAQMD rules), and verify that Hex Teflon Chevron packing, 1625G/Grafoil/1625G packing, and Graphaseal packing all experience VOC emission rates of less than 100 ppm.

Using these packing designs, you can trust Hex valves to do their part in helping you to adhere to the requirements of the Clean Air Act and state regulations.

Features and Benefits

■ Wide Selection of Packing Materials

Choose fully packed bonnets using Teflon Chevron (service up to 450°F), 1625G/Grafoil/1625G (service to 1000°F), or Graphaseal packing (service to 1000°F)

■ Valves Available for Special Needs

Models available to meet NACE MR-01-75 or as Power Valves to meet ANSI B31.1 or ANSI B31.3 specifications.

■ Backseated Bonnets with Packing Below the Stem Threads

Not only do our packing styles minimize emissions, the packing-below-the-threads design also eliminates potential thread contamination by the process media. The backseating further contributes to emissions reduction with a metal-to-metal backseat that also prevents accidental removal or stem blowout in operation.

VOC Emission Compliance

Applicable Models

The following Hex Valve models are certified to meet the test standards:

- HG/PG651...413; ...418 Primary Orifice Block Valves
- HG/PG46...418 Primary Gauge/Block Valves
- HN49...412; ...413; ...418 Needle Valves
- HG48...412; ...413; ...418 Gauge Valves
- HB50/59...412; ...413; ...418 Differential Pressure Equalizing Valves
- HM20/40/50/59...412; ...413; ...418 Gauge Pressure Manifolds
- HM45/46/53/54...412; ...413; ...418 Differential Pressure 3-Valve Manifolds
- HM56...412; ...413; ...418 Differential Pressure Blowdown Manifolds
- HM58...412; ...413; ...418 Differential Pressure Liquid Level Manifold

Notes

- Test conducted in accordance with EPA Reference Method 21 (40 CFR 60)
- Valves cycled before and during test
- Hold/test time 2-5 minutes
- Glands adjusted as in field audits
- Test pressure 1,000 psi with 17% Methane test gas

Emission Rate in Parts Per Million (PPM)

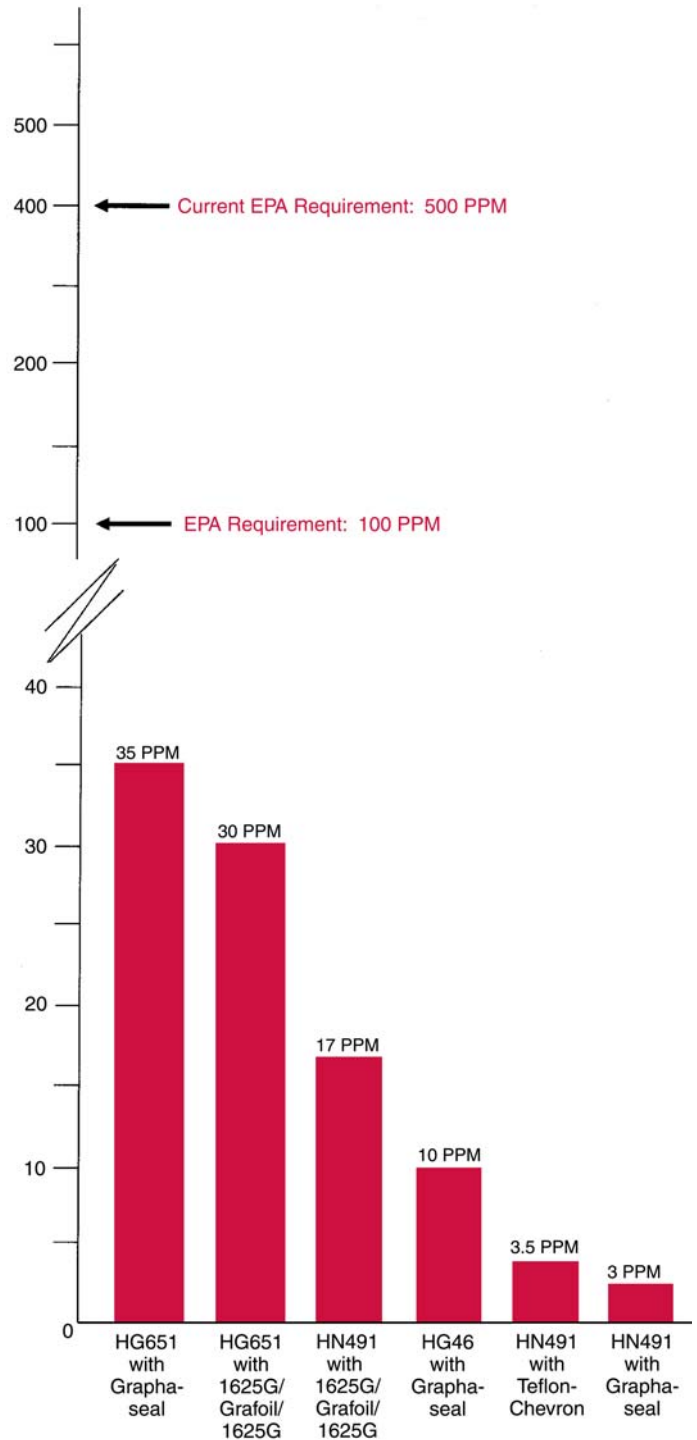



A Division of Richards Industries Valve Group
3170 Wasson Road • Cincinnati, OH 45209
Telephone: 513-533-5600 • 800-543-7311
Fax: 513-871-0105
E-Mail: info@richardsind.com
URL: www.hexvalve.com